





Nederlands.....	3	
Englisch.....	6	
Deutsch.....	9	
Français.....	12	

Dit apparaat voldoet aan de volgende EEG-richtlijnen:
 This appliance is in accordance with the following Directives:
 Dieses Gerät wurde in Übereinstimmung gemäß den folgenden Richtlinien gebaut:
 Cet appareil est conforme aux directives:



EMC 92/31/EEG &
93/68/EEG
LVD 73/23/EEG



RoHS 2002/95/EEG
WEEE 2002/96/EEG



FOOD 1935/2004/EEG

2007 Animo®

Alle rechten voorbehouden.

Animo behoudt zich het recht voor om onderdelen op elk gewenst moment te wijzigen, zonder voorafgaande of directe kennisgeving aan de afnemer. De inhoud van deze handleiding kan eveneens gewijzigd worden zonder voorafgaande waarschuwing. Deze handleiding is geldig voor de machine in standaarduitvoering. Animo kan derhalve niet aansprakelijk worden gesteld voor eventuele schade voortvloeiende uit van de standaard uitvoering afwijkende specificaties van de aan u geleverde machine. Voor informatie betreffende afstelling, onderhoudswerkzaamheden of reparaties waarin deze handleiding niet voorziet, wordt u verzocht contact op te nemen met de technische dienst van uw leverancier. Deze handleiding is met alle mogelijke zorg samengesteld, maar Animo kan geen verantwoording op zich nemen voor eventuele fouten in dit boek of de gevolgen daarvan.

All rights reserved.

Animo has the right to change parts of the machine at any time without preceding or direct announcements to the client. The contents of this manual can also be changed without any announcements. This manual is to be used for the standard model/type of the machine. Thus Animo cannot be held responsible for any damage resulting from the application of this manual to the version delivered to you. For extra information on adjustments, maintenance and repair, contact the technical department of your supplier. This manual has been written very carefully. However, Animo cannot be held responsible neither for mistakes in the book nor for their consequences.

Alle Rechte vorbehalten

Animo behält sich das Recht vor, Einzelteile ohne vorherige Bekanntgabe an den Kunden zu ändern. Der Inhalt dieser Anleitung kann ebenfalls ohne vorherige Bekanntgabe geändert werden. Diese Anleitung gilt für die Standardausführung der Maschine. Animo haftet daher nicht für Informationen über Einstellungen, Wartungsarbeiten oder Reparaturen, die nicht in dieser Anleitung enthalten sind. Wenden Sie sich bitte an den Kundendienst Ihres Händlers. Diese Anleitung wurde mit größtmöglicher Sorgfalt hergestellt. Animo haftet jedoch nicht für etwaige Fehler in dieser Anleitung oder für die Folgen solcher Fehler.

Tous droits réservés.

Animo se réserve le droit de modifier les pièces à n'importe quel instant, sans avis préalable et sans obligation de notification au client. Le contenu de ce manuel est également sujet à modification sans avis préalable. Ce manuel s'applique au modèle standard de la machine. Par conséquent, Animo n'est pas responsable pour les dommages éventuels découlant de l'application de ce manuel aux modèles non standard. Pour les renseignements sur certains réglages, les travaux d'entretien ou réparations qui ne seraient pas traités dans ce manuel, Animo ne peut être tenu responsable des erreurs éventuelles ni des dommages qui en découleraient.

PREFACE

Introduction

Congratulations on your purchase of one of our products. We hope that you will enjoy using it.

Models

This manual covers the following appliances:

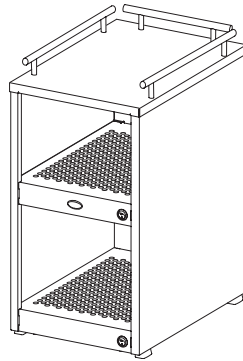

Fig. 1

KKW with saucer holder

Purpose of the appliance

The sole purpose of this appliance warm coffee cups and glasses.

The cup heater can be used as a stand-alone unit or as an additional device of your coffee machine.

The use of the appliance for other purposes is not permitted and may be hazardous. The manufacturer cannot be held liable for losses caused by using the appliance for purposes other than those indicated here or by incorrect use.

Guarantee conditions

The guarantee conditions applicable to this appliance form an integral part of the general terms of delivery.

Appliances and the environment

The packing material

Your new coffee maker has been carefully packaged to protect it against damage. The packing is not harmful to the environment and consists of the following materials:

- Corrugated cardboard
- Filler elements made of polyurethane foam <PUR> covered with a polythene film (>PE-HD<).

The waste processing plant in your municipality will be pleased to inform you about where you can dispose of the materials.

Discarding the appliance

No appliance lasts forever. When the time comes to discard your appliance it will usually be possible to return it to your dealer. If this is not the case, ask your municipal council about the alternatives for recycling the materials. All plastic parts have been given standard codes. The parts of the appliance such as the printed circuit board and accompanying parts form electrical and electronic waste. The metal pipes are made of stainless steel and can be completely dismantled.





Read these instructions for use carefully, before using this appliance. This will protect your safety and prevent damage being caused to the appliance. Perform the various actions in the order given. Always keep this manual close by the appliance.

1. GENERAL DESCRIPTION

Figure 2:

- A. ON/OFF switch lower cup warming tray
- B. Lower cup warming tray
- C. ON/OFF switch upper cup warming tray
- D. Upper cup warming tray
- E. Saucer holder

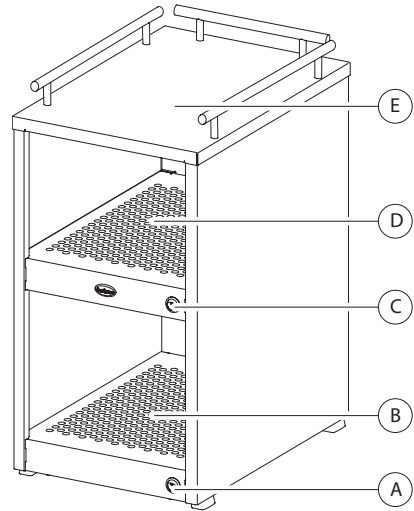

2. TECHNICAL DETAILS

Model	KKW-n
Article number	70037
Cup capacity	144 cups
Saucer holder capacity	50 sausers
Electrical connection	1N~ 220-240V
Frequency	50-60 Cy
Power consumption	140 W
Weight empty	11,6 kg
Weight filled	abt. 25 kg
Dimensions (last page)	fig. 3

Technical alterations reserved

Fig. 2

WARNING



- Always remove the plug from the socket if the machine has to be opened for repair or maintenance.
- Always plug the machine into an earthed wall socket.
- Do not submerge or spray the machine.
- Have all repairs carried out by a specially trained technician.
- Make sure that the mains cable does not come into contact with the cup warming tray which become hot when in use.

3. INSTALLATION



- only suitable for indoor use
- not suitable for use in humid areas
- not suitable for areas with explosion hazard



Preparation for positioning

- Place the appliance at buffet height on a firm, level base that can withstand the weight of the machine when filled.
- The power connection must be within half a metre of where the machine is positioned.

Unpacking

The machine has been carefully packed to prevent damage being caused to your new appliance. Remove the packing carefully without using sharp objects. Check if the appliance is complete. To protect the stainless steel parts from scratches these surfaces are temporary protected by a foil. This foil must be removed during installation.

Please contact your dealer in case parts are missing or damaged.

WARNING

- When the appliance is in use, some of the components will get very hot.
- Make sure that the mains cable does not come into contact with the cup warming tray which become very hot when in use.
- Please make sure that no water is poured on the cup tray.
- Do not dry towels on the device. The internal air circulation may be hindered and cause damage through overheating.

4. USE

1. Switch on the cup heater by setting the switches (fig. 2A & 2C) to the ON (I) position.
2. Place the (dry) cup and mugs (upside down) on the cup warming plateaus (fig. 2B & 2D). Saucers can be placed onto the (optional) saucer holder (fig. 2E).
3. The cup tray is heated automatically and functions most optimally when covered with cups.
4. Always switch off the cup warmer plateau when it is empty or when it is not being used. Switch it off by setting the switches (fig. 2A & 2C) to the OFF (0) position.

WARNING



- The machine should not be submerged or sprayed.
- Have all repairs carried out by a specially trained technician.

5. MAINTENANCE

Cleaning of the appliance and accessories

- Clean the outside of the appliance with a clean, damp cloth, if necessary using a mild (non-abrasive) cleaning agent.
- Do not use an abrasive, as this will leave scratches and dull patches.

Afmetingen / Dimensions / Abmessungen / Dimensions

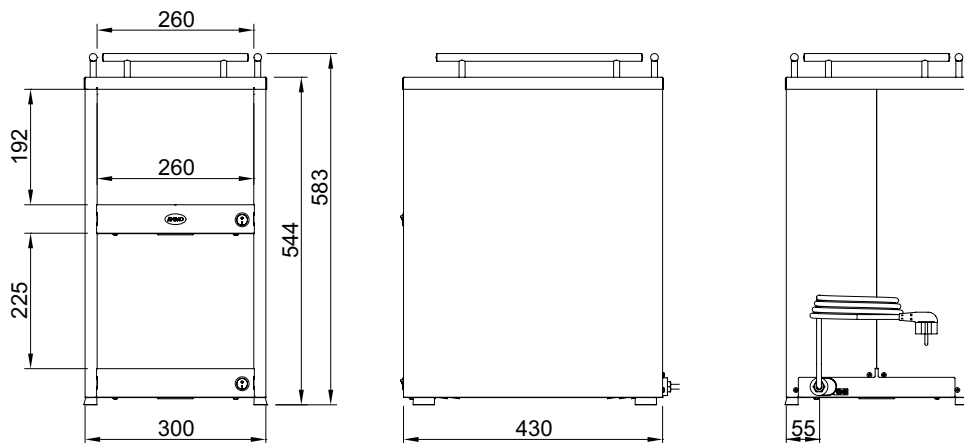

Fig. 3 / Abb. 3

KKW-n + schotelhouder

KKW-n + Saucer holder

KKW-n + Untertassenhalter

KKW-n + Plateau supérieur

ANIMO

Animo B.V.
Dr. A. F. Philipsweg 47
P.O. Box 71
9400 AB Assen
The Netherlands

Tel: +31 (0) 592 376376
Fax: +31 (0) 592 341751
E-mail: info@animo.nl

www.animo.eu

