

Animo

A 100 / A 200

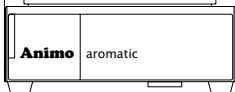
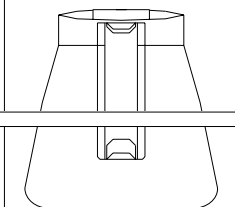
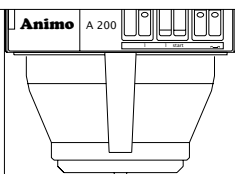
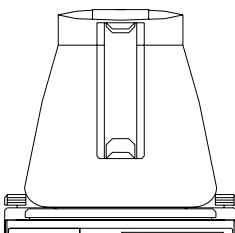

MANUAL

GB

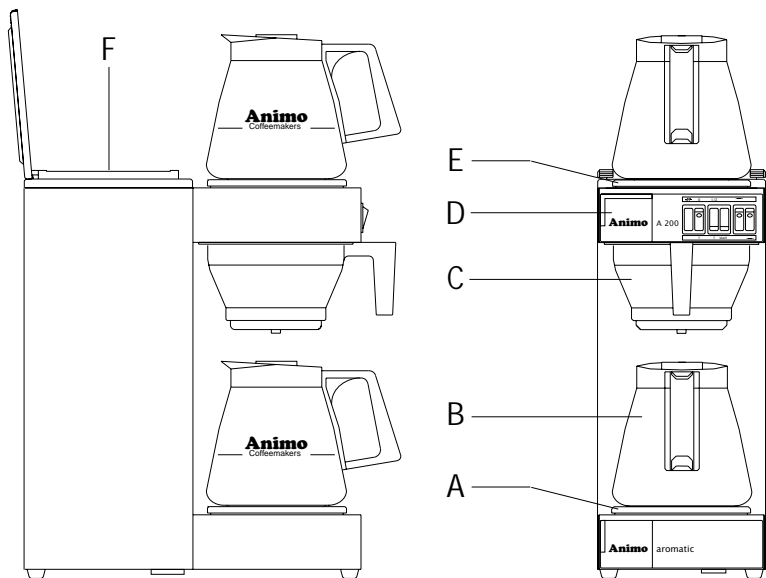

fig. 1

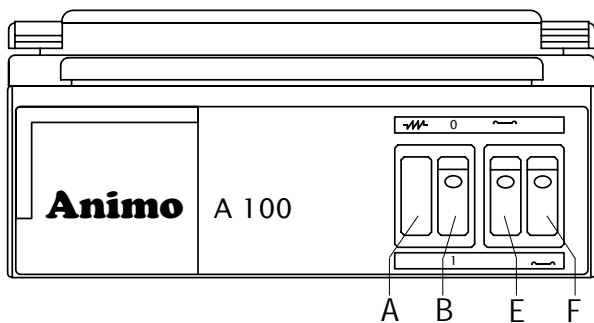

fig. 2

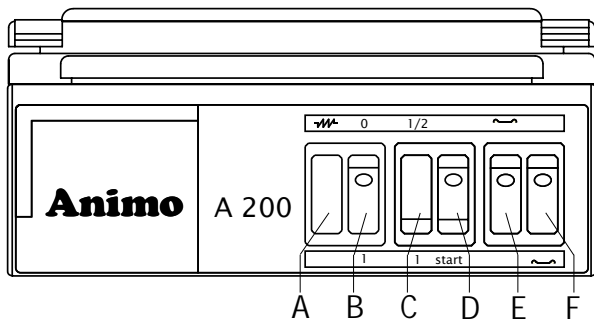

fig. 3

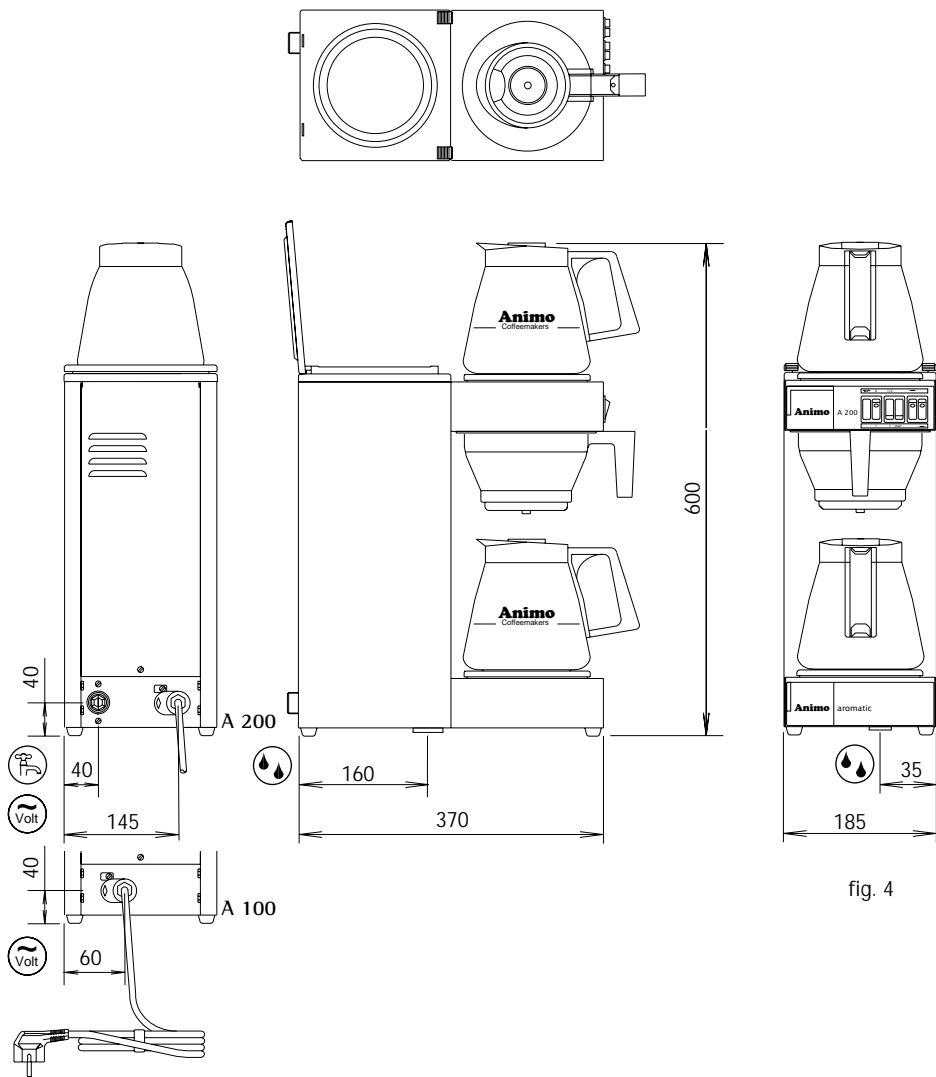

fig. 4



Dit apparaat voldoet aan de EMC-richtlijn 89/336/EEG, 92/31/EEG en de laagspanningsrichtlijn 73/23/EEG.

This appliance is in accordance with the EMC-Directive 89/336/EEC, 92/31/EEC and the low voltage directive 73/23/EEC.

Dieses Gerät wurde in Übereinstimmung gemäß EMV-Richtlinie 89/336/EWG, 92/31/EWG und Niederspannung-Richtlinie 73/23/EWG gebaut.

Cet appareil est conforme à la directive d'EMC 89/336/CEE, 92/31/CEE et à la directive de basse tension 73/23/CEE.

Animo behoudt zich het recht voor om onderdelen op elk gewenst moment te wijzigen, zonder voorafgaande of directe kennisgeving aan de afnemer. De inhoud van deze handleiding kan eveneens gewijzigd worden zonder voorafgaande waarschuwing. Deze handleiding is geldig voor de machine in standaarduitvoering. Animo kan derhalve niet aansprakelijk worden gesteld voor eventuele schade voortvloeiende uit van de standaard uitvoering afwijkende specificaties van de aan u geleverde machine. Voor informatie betreffende afstelling, onderhoudswerkzaamheden of reparaties waarin deze handleiding niet voorziet, wordt u verzocht contact op te nemen met de technische dienst van uw leverancier. Deze handleiding is met alle mogelijke zorg samengesteld, maar Animo kan geen verantwoording op zich nemen voor eventuele fouten in dit boek of de gevolgen daarvan.

Animo has the right to change parts of the machine at any time without advice or direct announcements to the client. The contents of this manual can also be changed without any announcements. This manual is to be used for the standard model/type of the machine. Thus Animo cannot be held responsible for any damage resulting from the application of this manual to the version delivered to you. For extra information on adjustments maintenance and repair, contact the technical department of your supplier. This manual has been written very carefully. However, Animo cannot be held responsible neither for mistakes in the book nor for their consequences.

Animo behält sich das Recht vor, Einzelteile ohne vorherige Bekanntgabe an den Kunden zu ändern. Der Inhalt dieser Anleitung kann ebenfalls ohne vorherige Bekanntgabe geändert werden. Diese Anleitung gilt für die Standardausführung der Maschine. Animo haftet daher nicht für Informationen über Einstellungen, Wartungsarbeiten oder Reparaturen, die nicht in dieser Anleitung enthalten sind. Wenden Sie sich bitte gegebenenfalls an den Kundendienst Ihres Händlers. Diese Anleitung wurde mit größtmöglicher Sorgfalt zusammengestellt. Animo haftet jedoch nicht für etwaige Fehler in dieser Anleitung oder für die Folgen solcher Fehler.

Animo se réserve le droit de modifier les pièces à n'importe quel instant, sans avis préalable et sans obligation de notification au client. Le contenu de ce manuel est également sujet à modification sans avis préalable. Ce manuel s'applique au modèle standard de la machine. Par conséquent, Animo n'est pas responsable pour les dommages éventuels découlant de l'application de ce manuel aux modèles non standard. Pour les renseignements sur certains réglages, les travaux d'entretien ou réparations qui ne seraient pas traités dans ce manuel, Animo ne peut être tenu responsable des erreurs éventuelles ni des dommages qui en découleraient.

TABLE OF CONTENTS

1.	GENERAL DESCRIPTION	2
2.	TECHNICAL DETAILS	2
3.	INSTALLATION	3
3.1	Position the machine	3
3.2	Connecting to the water supply system (A 200)	3
3.3	Connecting to the electricity supply system	3
4.	CONTROL PANEL	4
5.	PREPARATION BEFORE USE	4
5.1	A 100 (manual filling)	4
5.2	A 200 (automatic filling)	4
6.	USE	5
6.1	Brewing coffee	5
7.	MAINTENANCE	5
7.1	Cleaning (daily)	5
7.1.1	Removal of coffee fur	6
7.2	Descaling	6
8.	TRANSPORT	7

This instruction was designed for users of the Animo coffeemaker, type A 100 and A 200. These operating instructions should be read carefully to ensure that your coffee machine is operated correctly and safely.

1. GENERAL DESCRIPTION

The Aromatic A 100 is a semi-automatic coffee machine. The Aromatic A 200 is an automatic model with a fixed water connection and a selector switch to choose a full or a half jug of coffee. The machine is started by simply pressing the button. The flow through design eliminates initial water heating time and so provides a faster brew.

In figure 1 the main parts are indicated.
In figure 2 and 3 the controls are indicated.

Figure 1.

- A - Lower hot plate
- B - Glass jug 2x (art.nr. 08208)
- C - Basket filters (90/250) 2x (art.nr. 08635)
- D - Switch panel
- E - Upper hot plate
- F - Water reservoir

The machine is supplied with the following accessories:

- Measuring spoon
- Basket filter paper 90/250 approx. 50 pieces (art.nr. 01088 1000 pieces)
- Water supply hose approx. 1.5 m long (type A 200)
- 1 sachet coffee fur remover (100 sachets for 10 grams art.no. 49009)
- 1 sachet descaling agent (48 sachets for 50 grams art.no. 49007)
- Operating manual

2. TECHNICAL DETAILS

Type	: A 100	A 200
Article number	: 10295	10223
Approx. hourly capacity coffee	: 20 ltr., 160 cups	20 ltr., 160 cups
Buffer supply coffee	: 3,6 ltr., 29 cups	3,6 ltr., 29 cups
Brewing time	: abt. 5 min./1.8 Ltr.	abt. 5 min./1.8 Ltr.
Minimum amount of coffee	: 1/2 Jug	1/2 Jug
Electrical connection	: 1N-220-240V/50-60Cy/2275W	1N-220-240V/50-60Cy/2275W
Level detection	: electronic	electronic
Water connection	: n/a	G 3/4"
Min. - Max. water pressure	: n/a	1-8 bar
Paper filter	: 90/250	90/250
Dimension	: See fig.4	See fig.4
Weight	: 8 kg	8 kg

Technical alterations are reserved

WARNING

- * Always observe local rules while installing the unit and use approved materials and parts.
- * Always remove the plug from the socket if the machine has to be opened for repair or maintenance.
- * Do not put the machine in areas where the temperature drops below freezing point because there is always water left in the system.
- * Always plug the machine into an earthed wall socket.
- * Connect the machine to the cold watertap (type A 200).
- * Do not submerge or spray the machine.
- * Make sure that the main cable does not come into contact with the hot plates.
- * Have all repairs carried out by an especially trained technician.
- * If the machine is not used it is advisable to remove the plug from the socket and to turn off the water tap *. (type A 200).

3. INSTALLATION

Before installing the machine, carry out the following steps:

3.1 Position the machine

- at counter level and on a solid flat surface.
- so that it is near the water and electricity supply system.
- so that it is not causing any damage in case of leakage.
- so that the ventilation holes in the back of the appliance are not blocked.

3.2 Connecting to the water supply system (A 200)

- The machine requires water stop valve to be near the appliance.
- The water supply system should be within reach of the 1.5 meters long water hose.
- Connect the water hose that comes with the system to the cold water supply and to the water connection point at the back of the machine.
- When positioning the machine, bear in mind that it is equipped with an overflow.

3.3 Connecting to the electricity supply system

Depending on the model, the appliance should be connected according to the instructions in the figures below.

- (Fig. 5) For 220V-240V 1 Phase/neutral with plug socket.
- (Fig. 5) For 220V -240V 1 Phase/neutral (3 core electric cable).

The following remarks apply to figure 5:

- If the plug fitted on the machine cable does not fit in your socket, replace it with a new plug that does fit.
- The replaced plug should be disposed of as it can be dangerous if plugged in a socket.

The following points should be observed when wiring a new plug:

1. The green/yellow-coloured wire ("EARTH") should be connected to the terminal which is either marked with the letter "E", the "earth" symbol (\perp), or coloured green or green/yellow.
2. The blue-coloured wire ("NEUTRAL") should be connected to the terminal which is either marked with the letter "N" or coloured black.
3. The brown-coloured wire ("PHASE") should be connected to the terminal which is either marked with the letter "L" or coloured red.

IMPORTANT !

The three core main cables (fig. 5) have the following wiring code:

Green/Yellow - Earth
 Blue - Neutral
 Brown - Phase

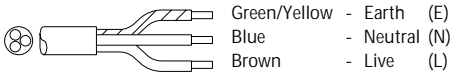

fig. 5

4. CONTROL PANEL**A 100 (manual filling fig. 2)**

A - Alarm lamp for heating element

B - On/off switch

E - On/off switch for upper hot plate

F - On/off switch for lower hot plate

A 200 (automatic filling fig. 3)

A - Alarm lamp for heating element

B - On/off switch

C - Selection switch for full or half jug

D - Start switch

E - On/off switch for upper hot plate

F - On/off switch for lower hot plate

5. PREPARATIONS BEFORE USE

Before operating the machine, carry out the following steps:

5.1 A 100 (manual filling)

1. Pour a jug of cold water in the cold water reservoir (fig. 1F).
2. Slide the basket filter into the machine and place an empty jug on the lower hot plate.
3. After you have followed the instructions above, place the plug in the socket and turn the machine on using the main switch (fig. 2B).
4. The orange alarm lamp (fig. 2A) will now light up until the machine has emptied. When the light goes out again the coffee unit is ready for use.

5.2 A 200 (automatic filling)

1. Connect the supplied water hose to the coupling nut swivel joint at the rear of the machine and to a manually-operated water tap. **ATTENTION!** Use cold water only.
2. Slide the basket filter into the machine and place an empty jug on the lower hot plate.
3. After you have followed the instructions above, place the plug in the socket.
4. Turn on the machine by using the switch (fig. 3B).
5. Turn the selection switch (fig. 3C) to the desired amount.
6. Press the start switch (fig. 3D) and the water reservoir will fill up.
7. The orange alarm lamp (fig. 3A) will now remain lit until the water has run through. The machine is ready for use when the lamp has gone out again.

6. USE

Basic rules for making coffee:

- Use extra-fine grind (approx. 40 grams per litre).
- Keep the thermos jug and the basket filters clean.
- Hint! Keep a pile of basket filter papers in the spare sliding filter or place a filter paper with coffee in this filter so that the next serving can be prepared without losing time.

6.1 Brewing coffee

1. Place the filter paper (90/250) with the appropriate amount of coffee (fine ground for filter coffee units) in the basket filter. The amount can be measured with the supplied measuring spoon. Generally speaking, you will need about 70 - 80 grams per 1.8 l jug.
2. Slide the basket filter into the machine and place an empty jug on the lower hot plate.
3. Check if the machine is switched on, main switch on (fig. 2B & 3B), and switch on the lower hot plate (fig. 2F & 3F).

A 100 (manual filling)

4. Pour a jug of cold water in the cold water reservoir (fig. 1F), and place the empty jug directly on the lower hot plate.

A200 (automatic filling)

4. Turn the selection switch (fig. 3C) to the required amount and press the start switch (fig. 3D).
5. The orange signal lamp (fig. 2A & 3A) on the machine will now light up and the filter coffee will be prepared.
6. When the signal lamp goes out again, the hot water supply will stop. After about 1 minute, all of the coffee will have gone through the filter.
7. Stir the coffee in the jug briefly and pour or place the full jug on the upper hot plate. The upper hot plate can be switched on separately using the appropriate switch (fig. 2E & 3E).
8. The machine is ready to be used again after the basket filter has been cleaned.

WARNING

- Stay near the machine while maintenance is being carried out.
- When descaling the machine, always observe the instructions for use provided with the descaling agent.
- When descaling the machine, it is advisable to wear safety goggles and protective gloves.
- Allow the machine to run through at least three times after it has been descaled.
- Wash your hands thoroughly after descaling.
- The machine should not be submerged or sprayed.
- Have all repairs carried out by a especially trained technician.

7. MAINTENANCE

- For daily cleaning, see section 7.1
- For removal of coffee fur, see section 7.1.1
- For descaling, see section 7.2

7.1 Cleaning (daily)

- The machine can be cleaned with a clean, damp cloth.
- Avoid using abrasive. It can cause scratches and dim spots.
- The jug and basket filter can be washed normally.
Attention! The basket filter should not be placed in a dishwasher.
- Coffee stains in the jugs can be removed using Animo coffee stain remover.
- The machine can leave lime deposits during use. The machine should be descaled regularly in order to ensure that it functions efficiently. Animo scale remover is recommended.

Animo supplies both products in the following quantities:

- Coffee detanning agent
100 sachets for 10 grams - art.no. 49009
- Descaling agent
48 sachets for 50 grams - art.no. 49007

7.1.1 Removal of coffee fur

A sachet of coffee fur remover solvent is supplied with the machine. Usage is extremely simple.

1. Take a bowl filled with ca. 5 litres warm water and dissolve the coffee fur remover solvent from the sachet into it.
2. Put the parts that need to be cleaned in the bowl and soak them for 15 to 30 minutes.
3. Rinse several times with warm water. Repeat treatment if the result is insufficient.
4. Scatter coffee fur remover solvent on very filthy spots and clean with a wet brush.

7.2 Descaling

1. Switch off the machine (fig. 2B & 3B).
2. Slide the basket filter into the machine and place an empty jug on the lower hot plate.
3. Dissolve 1 sachet of 50 grams of Animo descaling agent in 1 litre of lukewarm 60 - 70°C water (see instructions for use on the labelling).

A 100 (manual filling)

- 4a Pour 1 litre of Animo descaling agent into the reservoir (fig. 1F) and switch on the machine (fig. 2B). The solution will now begin to flow through the system.
- 4b Leave the reservoir lid open!

A 200 (automatic filling)

- 4a. Pour 1 litre of Animo descaling agent into the reservoir (fig. 1F) and switch on the machine (fig. 3B).
- 4b. Turn the selection switch (fig. 3C) to the half position and press the start button (fig. 3D). The solution will now begin to flow through the system.
- 4c. Leave the reservoir lid open!

- * Attention! If the machine begins to steam heavily, switch it off immediately (fig. 2B & 3B). Wait for 1 minute. The solution will flow through automatically. Switch the machine back on. Press the start button (fig. 2D) as well (A 200 only).

5. When half of the solution has run through the machine, switch it off for about 2 minutes (fig. 2B & 3B). The solution will now undergo a reaction with the lime scale.

6. After the pause, switch the machine back on and allow the rest of the solution to flow through the machine. Press the start button again (fig. 3D) (A 200 only).
- * Attention! Keep an eye on the reservoir while the solution is running through the machine. Turn the machine off as soon as the reservoir is empty. Then rinse clean the metal contacts in the cold water reservoir with water or a wet cloth.
7. After descaling the machine, rinse thoroughly by carrying out the normal coffee preparation process 3 times (without paper filters and coffee).
8. Clean the basket filter and jug thoroughly.
9. The machine is now ready to be used again.

8. TRANSPORT

The following procedure should be followed when the appliance is transported:

1. Switch off the machine (fig.2B & 3B) and remove the plug from the wall socket.
2. Close the water supply tap and disconnect the supply hose.
3. Remove the jugs and the basket filter.
4. Empty the machine, by turning it upside down above the sink, so that the remaining water runs out through the spray head (attention: the water can still be hot!)
5. Wipe the machine dry, and replace all the components that have been removed.
6. The machine is now ready for transport.
7. When it is relocated, the procedures of "Installation", should be followed.

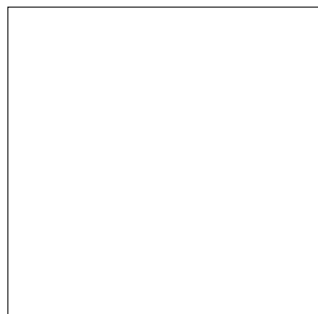
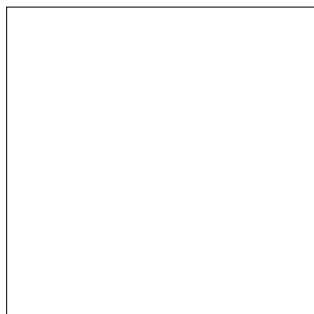
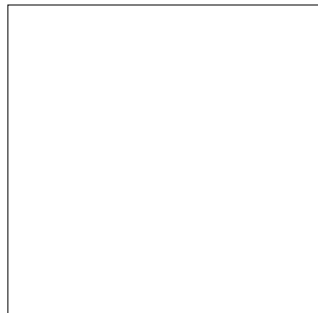
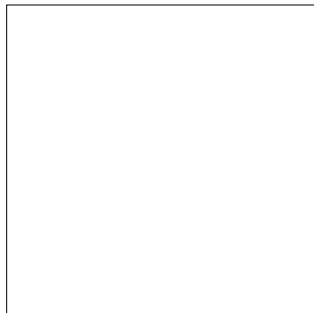
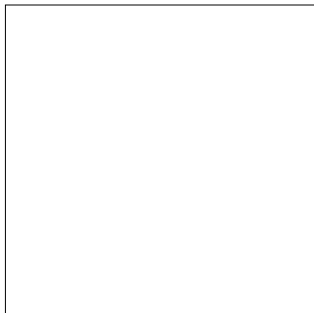

Animo B.V. Headoffice
Dr. A.F. Philipsweg 47
P.O. Box 71
9400 AB Assen
The Netherlands
Tel. no. +31 (0)592 376376
Fax no. +31 (0)592 341751
E-mail: info@animo.nl
Internet: <http://www.animo.nl>

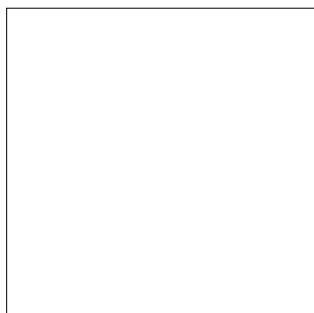

0394 Rev. 4 111099 **Animo** 09919



Accredited by
the Dutch Council
for Certification

