

Animo[®]

OPTIFRESH bean

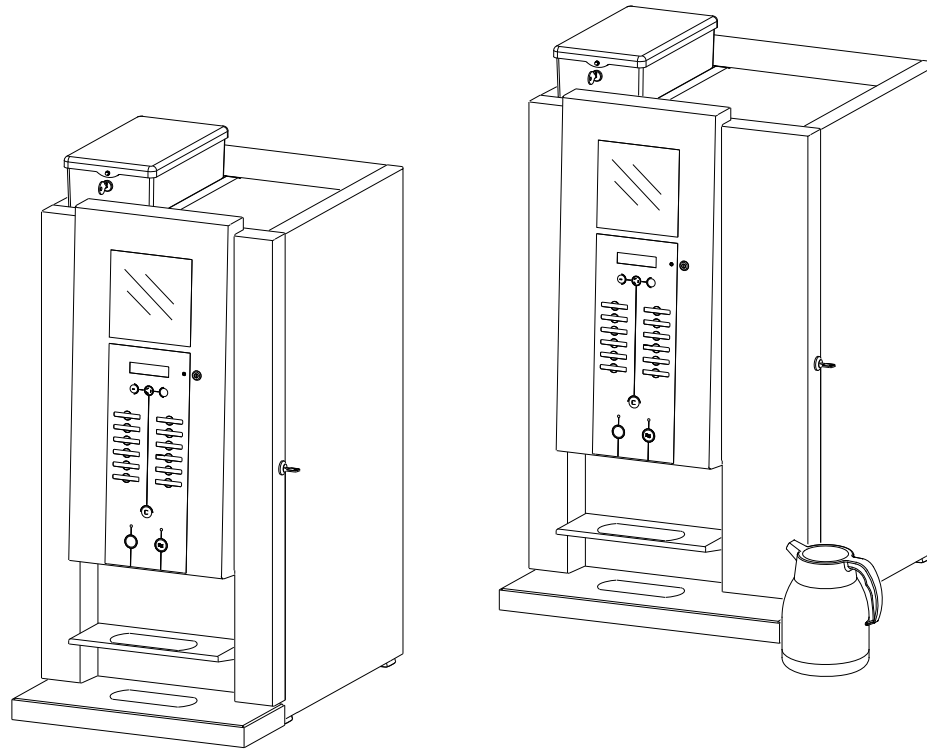

(NL) Gebruiksaanwijzing

(GB) Manual

(D) Betriebsanleitung

(F) Mode d'emploi

CONTENT

<i>PREFACE</i>	50
<i>Purpose of use</i>	52
<i>Safety instructions and danger warnings</i>	53
<i>Safety provisions</i>	54
<i>Devices and the environment</i>	54
1. GENERAL	55
2. TECHNICAL DATA	56
3. INSTALLATION	58
3.1 Unpacking.....	58
3.2 Placement preparation.....	58
3.3 Water connection.....	59
3.3.1 Water treatment.....	59
3.3.2 Stand alone pump set.....	59
3.3.3 Base cabinets.....	59
3.4 Electrical connection.....	60
3.5 Drip tray discharge.....	61
3.5.1 Applying info sticker.....	61
3.6 Applying recipe strips.....	61
3.7 Removing the transit safety.....	61
3.8 Standard recipe settings.....	62
3.9 Filling the canisters.....	63
3.10 Positioning.....	64
3.10.1 Positioning on the work top.....	64
3.10.2 Base cabinet.....	64
3.10.3 Base cabinet with coffee residue outlet.....	64
4. FIRST USE	65
4.1 First use / rinsing the hot water system.....	65
4.2 Operator / service menu settings.....	65
5. OPERATING PANEL	66
5.1 Operating panel (front).....	66
5.2 Service panel (inside the door).....	67
6. MENU STRUCTURE	68
6.1 The operator menu.....	68
6.2 Quick recipe.....	70
7. DAILY USE	71
7.1 Filling (up) the canisters.....	71
7.2 Preparations.....	71
7.3 Dispensing cups/goblets.....	72
7.3.1 Strength adjustment.....	72
7.4 Dispensing jugs.....	73
7.4.1 Jug volume.....	73
7.5 Payment systems (optional).....	74
7.5.1 Coin system.....	74
7.5.2 Coin changer.....	75

7.6 Automatic disabling functions.....	76
7.7 Display messages during use.....	76
8. MAINTENANCE	77
8.1 Door switch.....	77
8.2 Rinsing programmes.....	77
8.3 Cleaning daily.....	78
8.3.1 Cleaning the brewer unit.....	78
8.3.2 Emptying and cleaning the waste bin.....	78
8.3.3 Cleaning the mixer unit.....	79
8.4 Weekly cleaning.....	80
8.4.1 Cleaning the brewer filter / brewer chamber.....	80
8.4.2 Brewer filter cleaning.....	81
8.4.3 Replacing the brewer filter.....	81
8.4.4 Cleaning the coffee grinder.....	82
8.4.5 Removing the entire brewer.....	82
8.4.6 Cleaning the mixer unit.....	83
8.5 Monthly cleaning.....	84
8.5.1 Cleaning the brewer unit.....	84
8.5.2 Cleaning the mixer extraction filter.....	85
8.6 Cleaning the canister(s).....	86
8.6.1 Instant canister(s).....	86
8.6.2 Bean canister.....	86
8.7 Other maintenance.....	87
9. SETTING THE SERVICE MOMENT	88
10. TEMPERATURE SAFETY DEVICE	89
11. TRANSPORT / STORAGE	89
12. TROUBLESHOOTING	90
13. ORDERING CONSUMABLES AND ACCESSORIES	90

DIMENSIONS

OptiFresh 1,2 and 3 bean.....	186
OptiFresh 4 bean.....	187
OptiFresh 1, 2, 3 bean Coin mechanism.....	188
OptiFresh 4 bean Coin mechanism.....	188
OptiFresh 1, 2, 3 bean Coin changer.....	189
OptiFresh 4 bean Coin changer.....	189
Base cabinet standard.....	190
Base cabinet with litter bin.....	190

© 2009 Animo®

All rights reserved.

No part of this document may be reproduced and/or made public in print, microfilm, electronic media or any other form without the manufacturer's prior consent. This also applies to the corresponding diagrams and/or charts.

Animo retains the right to alter parts at any given time without prior or immediate announcement to the consumer. The content of this manual can also be changed without any prior warning. This manual is valid for the standard model of the device. Animo can therefore not be held liable for possible damage resulting from specifications deviating from the standard model for the device supplied to you.

This manual does not provide information on settings, maintenance work or repair. If you would like any information regarding this, please contact the technical department of your supplier.

This manual was created with the utmost care, but the manufacturer cannot be held responsible for any mistakes in this document or their consequences.



Please carefully read the instructions in this document: they provide important instructions on safety during installation, use and maintenance. Keep this document in a safe place so that you can consult it at all times.

PREFACE

Objective of this document

This document provides directions for use for authorised staff to safely use and maintain this device.

- Authorised staff is considered to be those who operate and maintain the device and can solve small malfunctions.

All chapters and paragraphs are numbered. The various figures referred to in the text can be found in the figures section at the beginning of the manual or with the corresponding subjects.

Pictograms and symbols.



CAUTION

General indication for: IMPORTANT, CAUTION or REMARK.



WARNING

Warning for possible severe damage to the device or injury.

Introduction

First we would like to congratulate you with your purchase of one of our products. We hope you will enjoy using it.

Models

These instructions for use are for the following devices:

OptiFresh 1 bean
OptiFresh 2 bean
OptiFresh 3 bean

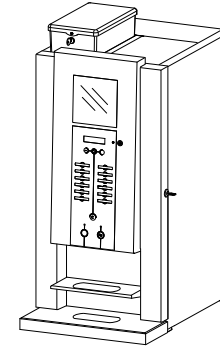

OptiFresh 4 bean

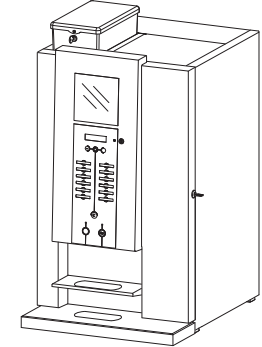

Coin mechanism (option)

OptiFresh 1 bean
OptiFresh 2 bean
OptiFresh 3 bean

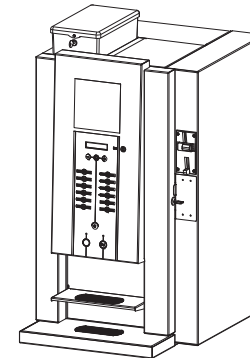

OptiFresh 4 bean

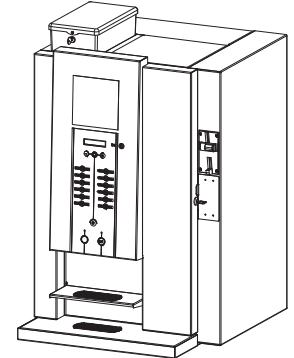

Purpose of use

This device can only be used for preparing hot drinks.

Use for any other purpose is inadmissible and can be dangerous.

The manufacturer cannot be held liable for any damages caused by use for any other purpose than what is described here or by incorrect operation.

Service and technical support

For information regarding specific settings, maintenance and repair work, which is not included in this document, please contact your dealer. Write down in advance the following data for your device indicated with a #. The below information can be found on the type plate on your device.

- A - Model indication #
- B - Article number #
- C - Machine number #
- D - Electrical connection
- E - Frequency
- F - Power

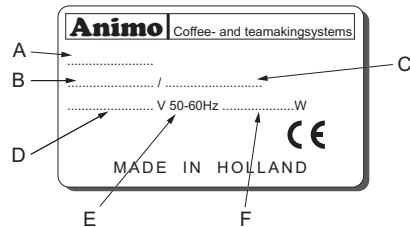

Guarantee provisions

The guarantee provisions that apply to this device are part of the general terms of delivery.

Directives

This device meets the following EEC directives:

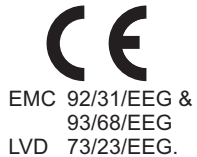

Conditions of the environment

Some water will always remain in the heating system. Therefore never place the device in an area where the temperature can drop below freezing. The operation of this device is guaranteed up to an ambient temperature of 40°C.

Recommended maintenance products

Descaler : Animo scale remover

Detergent : Animo coffee fur remover

See Chapter 13 for ordering these maintenance products.

Recommended ingredients

Brewer only use coffee beans

Mixers only use instant products

Safety instructions and danger warnings

This device meets the prescribed safety provisions.

Individuals can be injured and material damage can be caused by inappropriate use.

Before the device can be used safely, the following warnings and safety instructions must be observed:

Instructions for use



Please carefully read these instructions before using the device. It is safer for you and will prevent damage to the device.

Please adhere to the order of the following actions. Always store these instructions for use close to the device.

Installation

- Place the device at work top height on a firm, flat surface so that it can be connected to the mains.
- Plug the device into a safety-grounded power outlet.
- Position the device so that it cannot cause any damage in case of any leakage.
- Never tilt the device. Always position and transport the device upright.
- Some water will always remain in the heating system, so never place the device in a room where the temperature can fall below freezing.
- Always observe local regulations and use approved materials and parts.
- When reinstalling the device, please follow the 'Installation' chapter.

Use

- Inspect the device before use and check whether it is in any way damaged.
- The device must not be submerged or hosed down.
- Never operate the buttons with a sharp object.
- Keep the operating controls free of dirt and grease.
- If the device is not used for a long time, it is advisable to unplug the device and shut down the water supply.

Maintenance and solving malfunctions

- Overdue maintenance of the heating system can lead to high repair costs and can render the guarantees invalid.
- Do not leave the device during maintenance work.
- Have all repairs done by trained, authorised service engineers.
- If the device must be opened up because of faults or (cleaning) work, make sure that it is unplugged.
- If the safety instructions are not followed, the manufacturer cannot be held responsible for any resulting damage.

Safety provisions

This device has the following safety provisions:

Door switch (1-16)

The machine has a door switch that automatically switches off the machine when the door is opened. [Out of order Door open]. The machine can be switched on whilst the door is open (for example for cleaning) by inserting the supplied service pin in the door switch.

Temperature safety device (fig. 1-6)

The device has a temperature safety device that is accessible from the outside. It is located at the back of the device (fig. 1-6). The safety device turns off the heating element if the temperature is too high. This is usually caused by not descaling the device in time.

On/off switch (fig. 1-18)

The on/off switch turns the device on and off. The device can still be charged after it is switched off! In order to ensure that the machine is entirely uncharged, please unplug it.

C switch (Cancel) (fig. 1-4.4)

The dosages of a coffee jug recipe can be stopped simply by pressing the Cancel button. After the Cancel button is pressed, the selected coffee jug recipe is cancelled and the quantity for only one cup is dispensed.

Display warnings (fig. 1-4.1)

Technical malfunctions are shown on the display by means of an error code (e.g. E1). In that case, read **12. Troubleshooting**.

Display warnings (fig. 1-4.1)

If the drip tray is too full, this is shown on the display [*Out of order Drip tray full*] and the operating panel is disabled. Once the drip tray is emptied, the display message automatically disappears and the operating panel becomes functional again.

Devices and the environment

Packaging materials

In order to prevent that your new purchase is damaged, the machine is carefully packaged. The packaging does not harm the environment and mainly consists of the following materials:

- Corrugated cardboard
- Filler elements made of polyurethane foam >PUR< covered in a polyethylene film >PE-HD<. Contact the waste depot of your local council for the removal of these materials.

Replacement of the device

Not one device lasts forever. If you wish to replace your device, it is usually taken back in consultation with your dealer. If not, please contact your local council for the possibilities of re-using the materials. All synthetic parts are coded in a standardised way. Device parts such as circuit boards and their components come under electric and electronic waste. The metal casing is made of stainless steel and be entirely taken apart.

1. GENERAL

Major parts (fig.1)

1. Illustration
2. Cups tray (can be folded in)
3. Drip tray
4. Operating panel
 - 4.1 Display
 - 4.2 Strength setting
 - 4.3 Drink selection 12x
 - 4.4 Correction / Stop button
 - 4.5 Drink dispensing button
 - 4.6 Water dispensing button
 - 4.7 Jug lock
5. Coin mechanism (optional)
6. Dry-boil protection
7. Fan
8. Water connection
9. Electricity lead
10. Operator panel
 - 10.1 Stand-by
 - 10.2 Open brewer
 - 10.3 Clean mixer(s)
 - 10.4 Operator menu
 - 10.5 Clean brewer
11. Door lock
12. Brewer unit
13. Drink outlet
14. Hot water outlet
15. Waste bin coffee residue
16. Door switch
17. Boiler draining tube
18. On/off switch
19. Mixer unit(s)
20. Dispensing bent pipe(s)
21. Instant canister
22. Grinder
23. Bean canister

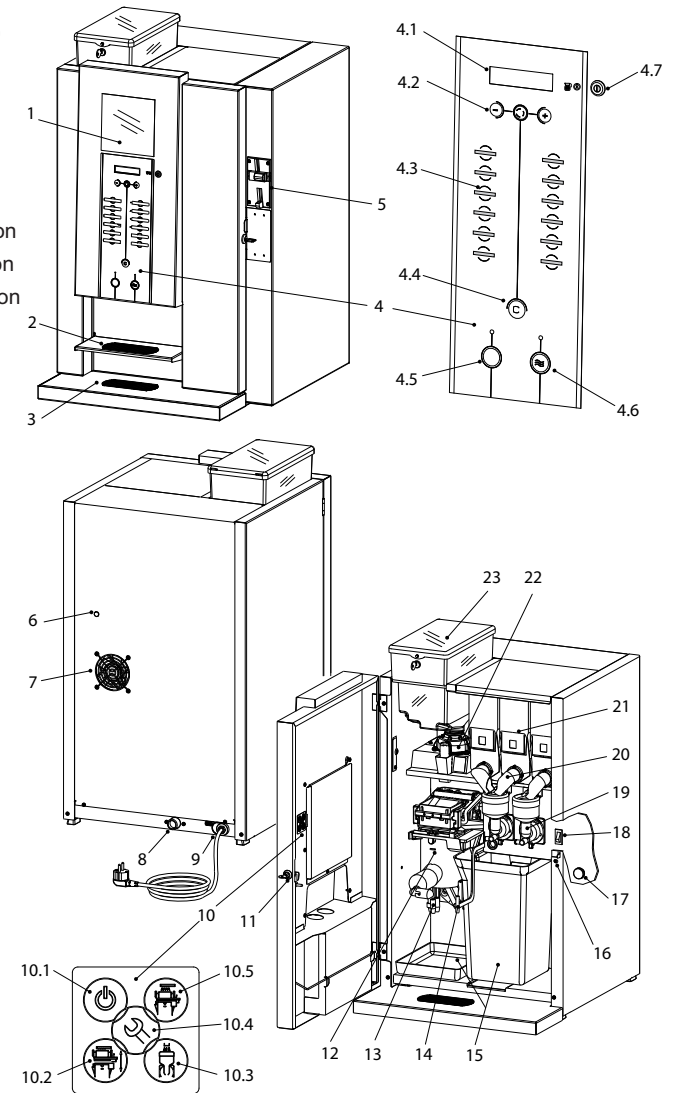

Fig. 1

OptiFresh 4 bean is model shown

2. TECHNICAL DATA

Model	OptiFresh bean
Capacity Coffee	
Hour capacity per cup of 120 ml	125 cups
Preparation time per cup of 120 ml	abt. 29 sec.
Preparation time jug (12 x 120ml cups)	5'.50"
Preparation time jug (7 x 200ml cups)	3'.23"
Canister capacity	see table 1
Capacity Cocoa	
Hour capacity per cup of 120 ml	300 cups
Preparation time per cup of 120 ml	abt. 12 sec.
Capacity hot water	
Hour capacity per cup of 120 ml	300 cups
Preparation time per cup of 120 ml	abt. 6 sec.
Preparation time jug (12 cups)	abt. 75 sec.
Hour capacity hot water	abt. 36 liter
Boiler volume	3 liter
Boiler heating time	7,5 min.
Electrical system	
Voltage	1N~ 220-240V
Frequency	50-60Cy
Total power	2300W
Heating element power	2200W
Fuse	10 A
Safety class	I
Internal circuit	24VDC
Power consumption	see table 3
Water system	
Water hardness	min. 5°dH
Water conductivity	70 µ Siemens/cm
Water connection	3/4" external pipe thread
Adjustable water temperature	70 - 97 °C
Min.-max water pressure	0,2 MPa (2 bar) - 1 MPa (10 bar)
Flow pressure	6 l. / min.
Materials	
Casing / door	stainless steel
Boiler	stainless steel 18/10 (1.4404) (AISI 316L)
Drip tray	plastic <PS> black
Dimensions	see last pages of this document
Weight	see table 2

All technical details are subject to change

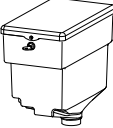
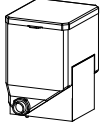

TABLE 1		Canister / waste bin capacity			
Ingredient	Dimensions	Volume	Product	Cups/120 ml	OptiFresh model
Coffee beans		6,4 ltr.	2500 gr.	300 cups (à 8 gr)	1-2-3-4
Milk/ Topping		5,1 ltr.	2200 gr.	-	2
Cocoa			3400 gr.	170 cups	2
Milk/ Topping		2,3 ltr	1000 gr.	-	3-4
Cocoa			1600 gr.	80 cups	3-4
Sugar			2000 gr.	-	4
Coffee [instant]			500 gr.	325 cups	2-3-4
Waste bin		7,7 ltr.		240 cups	1-2-3-4

TABLE 2	Weights (kg)		
Model	empty	filled*	in packaging
OptiFresh 1 bean	35	40	
OptiFresh 2 bean	35	44	
OptiFresh 3 bean	35	43	
OptiFresh 4 bean	39	47	

* = full ingredient canisters and boiler

TABLE 3	Power consumption [Wh]			
Model	To reach operating temperature	Operating mode ¹	Operating mode ²	For each hour stand by ³
OptiFresh 1, 2, 3 & 4	286	67	100	30

¹ without dispensing / ² dispensing of 200ml coffee each 30 minutes / ³ boiler kept warm on 60°C

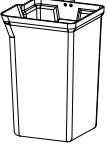
3. INSTALLATION

This device should only be placed and connected by an authorised service engineer. The following must be taken into account:

- Only suitable for indoor use 
- Unsuitable for use in damp areas
- Unsuitable in areas with a risk of explosion

3.1 Unpacking

In order to prevent any damage to your new purchase, the device is carefully packaged. You should carefully remove the packaging without using any sharp objects. Check whether the device is complete. In order to protect the device, the stainless steel sections are partly wrapped in protective foil. This foil should be removed during installation.

The device is supplied with the following accessories:

(Some accessories are located in the litter bin next to the brewer.)

	Number		Number
Coffee residue litter bin	1	Extra permanentfilter brewer	1
Reception tray brewer	1	Recipe strips (set)	1
Drip tray + grid	1	User manual	1
Door keys	2	Service manual	1
Jug lock keys	2	Disassembly equipment filter	1
Service pen	1	1.5 m Connection hose	1
Coffee fur remover (sachet)	1	0.5 m Drain hose (Drip tray)	1

If some parts are missing or damaged, please contact your dealer.

WARNING

Some water will always remain in the heating system. Therefore never place the device in an area where the temperature can drop below freezing.

3.2 Placement preparation

- Place the device at work top height on a firm, flat surface so that it can support the weight of the (filled) device.
- Make sure that the device is level and cannot cause damage in case of any leakage.
- Make sure that the ventilation openings at the back of the device are not obstructed.
- The water supply and electricity plug should be no further than half a meter away from the position of the device.
- These installation technical preparations must be out sourced by the user and should be carried out by an authorised fitter according to the general and local regulations.
- Only the service engineer can connect the device to the prepared connection points.

3.3 Water connection

Connect the device to a well accessible tap with air valve, which can be turned off quickly in case of problems. The minimal water pressure must not fall below 1 bar (at 5 l/min flow pressure).

If necessary, the OptiFresh can be connected to hot water. We explicitly advise you to use a special hot water connection tube (fig. 2).

- Hot water connection tube Art. No. 08175.

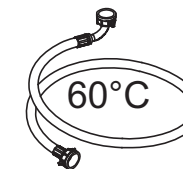

Fig. 2

3.3.1 Water treatment (fig. 3)

We explicitly advise you to use a water softener and/or water filter if the tap water has been chlorinated or is too hard. This increases the quality of the drink and will ensure that you do not have to descale the device too often.

- Filter system Brita AquaQuell 1.5 Art. No. 99681 incl. filter template and connection tube set
- Filter template Brita AquaQuell 1.5 Art. No. 07996

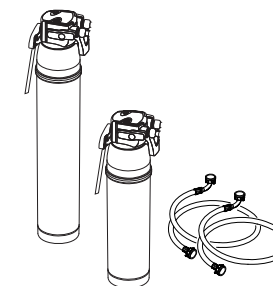

Fig. 3

3.3.2 Stand-alone pump set (fig. 4)

If no fixed water connection point is present near the machine, a stand-alone pump set can be supplied as an option.

- Water pump stand-alone Art. No. 93500
- Water tank 18 litre stand-alone Art. No. 01013

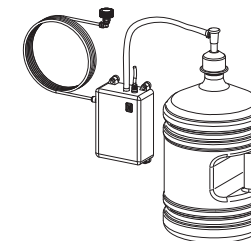

Fig. 4

3.3.3 Base cabinets (fig. 5)

A number of base cabinets are available as an option for the OptiFresh fresh brew machine.

- Base cabinet Art. No. 65070
Prepared for building in a stand-alone pump set and for fitting a water filter at the back.
- Work top large Art. No. 03390
- Work top small Art. No. 03357
- Base cabinet with transit Art. No. 65060
Prepared for building in a collection unit for collecting more coffee residue and for fitting a water filter at the back. This base cabinet does not have a drawer!
- Transit work top large Art. No. 65031
- Transit work top small Art. No. 65032

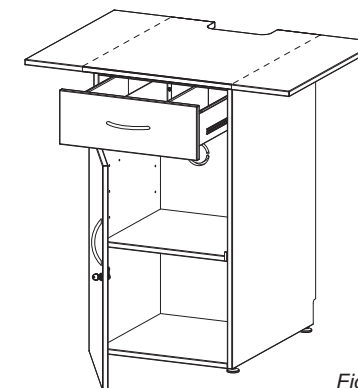

Fig. 5

3.4 Electrical connection

⚠ WARNING

- Supply voltage and frequencies can differ per country.
- Check if the appliance is suitable for connection to the local power mains.
- Check if the details on the type plate (fig. 6) correspond.
- Connect the appliance to an earthed wall socket.

The earthed wall socket and the fused group with a main switch belong to the electrical installation. No heavy machines that could cause variations in power when being switched on, can be connected to this group.

A machine with power current (two or three phase) is supplied from the factory without plug. At delivery, the machine must be provided with an electrically suitable plug as advised and provided by the installer. Depending on the appliance's electrical set-up, it must be connected as below.

- (fig. 7) 1 N~ 230V (3 core cable)
 (fig. 8) 2 N~ 400V (4 core cable)
 (fig. 9) 3 N~ 400V (5 core cable)
 (fig. 10) 3 ~ 230V (4 core cable)

The following points should be observed when wiring a new plug:

1. The GREEN/YELLOW colored wire [EARTH] should be connected to the terminal which is either marked with the letter [PE], the "earth" symbol (⏚), or colored green/yellow.
2. The BLUE colored wire [NEUTRAL] should be connected to the terminal which is either marked with the letter [N] or colored black.
3. The BROWN, BLACK and GRAY colored wire [PHASE] should be connected to the terminal which is either marked with the letter [L1, L2 and L3].

 If the installation instructions are not met, the supplier cannot be held liable for any consequences.



Fig. 6

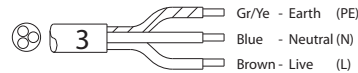

Fig. 7

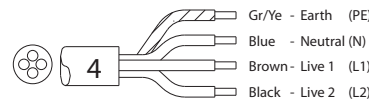

Fig. 8

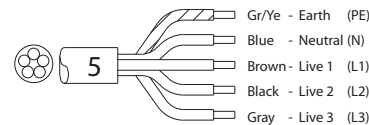

Fig. 9

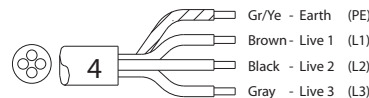

Fig. 10

3.5 Drip tray discharge

It is possible to fit a waste hose to the drip tray.

In order to do so, please remove the synthetic plug from the connection at the back (fig. 11) and apply the waste hose.

3.5.1 Applying info sticker

Apply (if desired) the information sticker (Figure 11) next to the control panel so a user easily can see which buttons to push.

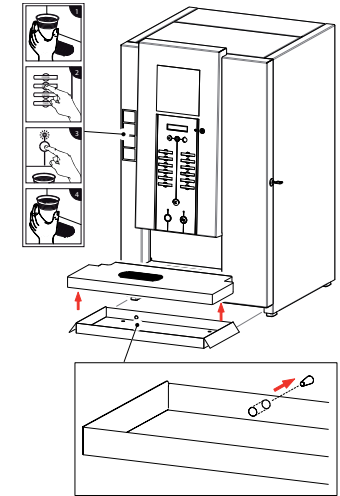

Fig. 11

3.6 Applying recipe strips

The factory does not yet apply the recipe strips next to the buttons. The device is always delivered together with a sheet of various recipe strips.

Please slide the recipe strip that is applicable to your situation in the window next to the corresponding button (fig. 12).

Section 3.8 **Standard recipe settings** will show you which recipes (drinks) correspond to the factory setting.

The service appendix (chapter 3) describes how every individual recipe (drink) can be set. After you set a modified recipe, make sure you slide the appropriate slide-in strip into the window next to the corresponding button.

If your dealer took the service attachment away after installing the device, then please contact your dealer.

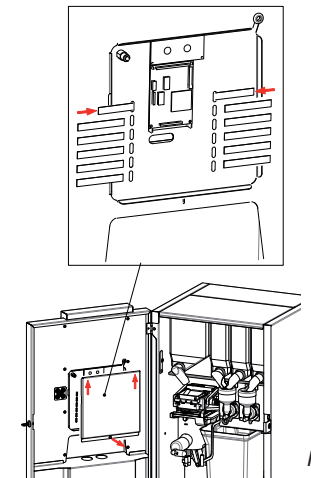

Fig. 12

3.7 Removing the transit safety

The brewer has been secured at the factory for safe transportation.

The transit safety must be removed before you start using the device (fig. 13) so that the brewer can be taken out of the machine for cleaning.

Attention: tighten the screw that fixed the transport safety again.

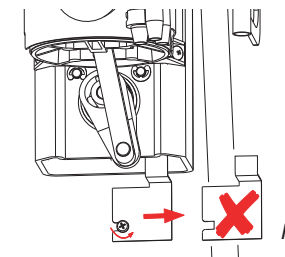

Fig. 13

3.8 Standard recipe settings

Table 1	OptiFresh BEAN 1	OptiFresh BEAN 2	OptiFresh BEAN 3	OptiFresh BEAN 4	
Canisters	1	Coffee beans	Coffee beans	Coffee beans	Coffee beans
	3	-	Chocolate	Chocolate	Chocolate
	4	-	-	Topping	Topping
	5	-	-	-	Instant Coffee
Button					
Standard recipes	1	☹ Coffee black	☹ Coffee black	☹ Coffee black	☹ Coffee black
	2	-	Hot chocolate	Coffee Milk	Coffee Milk
	3	-	Coffee chocolate	Hot chocolate	Hot chocolate
	4	-	-	Coffee chocolate	Coffee chocolate
	5	-	-	Cappuccino	Latte Macchiato
	6	-	-	Wiener Melange	-
	7	-	-	Latte Macchiato	Coffee Latte inst.
	8	-	-	-	Chocolate Milk
	9	-	-	-	Espresso inst.
	10	-	-	-	Wiener Melange inst.
	11	-	-	-	Cappuccino inst.
	12	☹ Hot Water ≡	☹ Hot Water ≡	☹ Hot Water ≡	☹ Hot Water ≡
Optional recipes #		Espresso	Espresso	Espresso	Espresso
		Double Espresso	Double Espresso	Double Espresso	Espresso Choc
		Jug Coffee	Espresso Chocolate	Espresso Chocolate	Coffee Latte
		Jug Hot Water ≡	Jug Coffee	Chocolate Milk	Coffee inst. Milk
			Jug Hot Water ≡	Hot Milk	Hot Milk
				Coffee Latte	Coffee Crème inst.
				Jug Coffee	Wiener Melange
		☹ JUG key switch		Jug Hot Water ≡	Latte Macchiato inst.
		JUG direct choice			Cappuccino
		≡ Water dispensing button (right)			Jug Coffee
	inst. = Recipe made with instant coffee			Jug Coffee inst.	
				Jug Hot Water ≡	

= can be programmed by dealer only

3.9 Filling the canisters

Fill the ingredient canisters with the relevant instant product according to table 1 (left).

Coffee bean canister

1. Open the bean canister (fig. 14) with the key.
2. Fill the canister (fig. 15) with coffee beans.
3. Close the canister again.

Fill the transparent canister only with **coffee beans!**

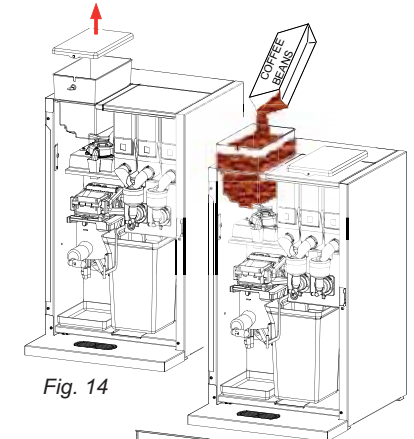

Fig. 14

Fig. 15

Instant canisters

1. Open the device lid (fig. 16).
2. Turn the dispensing outlet(s) into a horizontal position.
3. Move the canister(s) forward and take them out of the device.
4. Fill the canister(s) with the appropriate products (fig. 17). See table 1 on the left.
5. Place the canister(s) back in the right order.

Make sure that the drive mechanism of the canister falls over the cog in the back wall and that the fastening ridge goes into the hole of the plate (fig. 18).

6. Turn the dispensing outlet(s) back to their correct position (fig. 19).

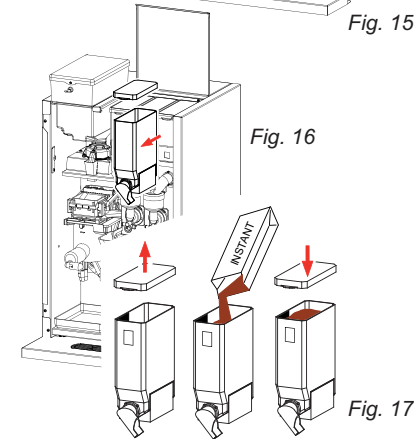

Fig. 16

Fig. 17

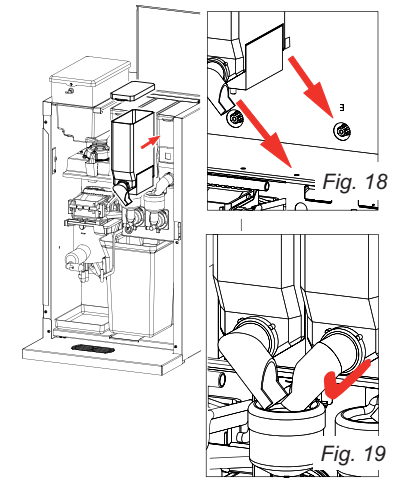

Fig. 18

Fig. 19

3.10 Positioning

3.10.1 Positioning on the work top

1. Position the device on an appropriate flat work area.
2. Allow an area of at least 11 cm to the left of the device so that the door can be opened.
3. Allow an area of at least 22 cm above the device so that the lid can be opened all the way.
4. Check whether the specifications of the type plate correspond to the mains voltage.
5. Connect the device to the water mains with the supplied connection tube.
6. Close the door and place the drip tray under the machine. It is possible to fit a waste hose on to the drip tray (chapter 3.5). Remove the synthetic plug and slide the hose on.
7. The device is now ready for first use.

3.10.2 Base cabinet (fig. 20)

Follow the instructions provided with the base cabinet.

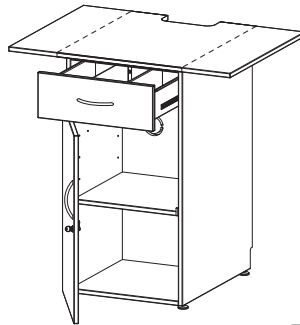

Fig. 20

3.10.3 Base cabinet with coffee residue outlet (fig. 21)

This base cabinet is designed to collect large quantities of coffee residue. The residue is led into the base cabinet through a (prepared) opening in the bottom section of the machine and is collected in a 37 litre collection bucket.

Follow the instructions provided with the base cabinet.

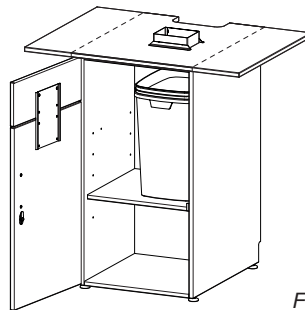

Fig. 21

4. FIRST USE



Before using the device for the first time, chapter 3. INSTALLATION must be completed.

- During its first use, the device works according to its standard factory settings.
- The various settings can be modified later by trained, authorised service staff. Please see the separate service appendix, chapter 2.2. THE SERVICE MENU.
- This chapter is about rinsing the hot water system if the device is about to be used for the first time or if the device has been out of operation for more than 1 week, for example after the holidays.

4.1 First use / rinsing the hot water system

1. Turn the water tap open and check whether the swivel connections do not leak.
2. Plug the device into an earthed socket.
3. Turn the device on by switching the ON/OFF switch (fig. 1-18) on. The display lights up and there is a beeping sound.
4. The display first shows the following words [*Out of order, Boiler Filling*] and then [*Out of order, Boiler Heating*]. During the heating phase, the settings of the device can be adjusted as described in the next chapter 4.2.
5. After approx. 5 minutes the device has heated up and the following words appear [*Make your choice*].
6. Place an empty cup of at least 120 ml under the relevant outlet and select your drink.
7. The drink in question is prepared. Please discard the first 2 cups of every choice of drink.
8. Again make a choice of drink and check whether the taste and quantity is appropriate. Repeat this for every drink. If taste and quantity are fine, then the device is ready for use.
9. If the taste and/or quantity do not meet your wishes, please read chapter 6.2 Quick recipe.

4.2 Operator / service menu settings

The following data must be set in the operator and service menus immediately after the machine's first use. The language factory setting is English.

Operator menu: press  on the service panel at the inside of the door.

- **1.1 Clock**
 - 1.1.0 Time (present time)
 - 1.1.1 Date (present date)
- **1.7 PIN-code** (see chapter 2.1 of the service appendix)
- **2.4 Settings** (Settings)
 - 2.4.0 Language (Language)
- **2.6 Descaling / filter**
 - 2.6.0 Time for service (descaling / filter counter)

Leave the menu by pressing  again on the service panel.

Study the rest of the setting options of the service menu later.
The device is now ready for use.

5. OPERATING PANEL

The device has two operating panels.

- The front operating panel (fig. 22) is for normal daily use.
- The operating panel at the inside of the door (fig. 23) can be used by the operator to gain access to the operator and service menus (only with PIN code).

CAUTION

- Never operate the buttons using a sharp object.
- Keep the operating controls free of dirt and grease.

5.1 Operating panel (front)

A. Illuminated Display

B. Strength setting for coffee, milk and sugar.

- You can choose the ingredient for which you wish to set the strength with the Set button .
- You can set the strength with the +/- button.

C. Option button 12x, set as mentioned in chapter 3.8

D. Correction / Stop button for correcting made choices and stopping (aborting) the dosage of a jug.

E. Drink dispensing button + LED. Blue LED flashes to indicate dispensing position of the goblet/cup. The LED is on consistently during the dosage until the drink is ready.

F. Water dispensing button + LED. Blue LED flashes to indicate dispensing position of the goblet/cup. The LED is on consistently during the dosage until the drink is ready.

G. Menu navigation buttons 7 to 10 have a second function after the operator menu has been activated.

H. Jug lock, After activating the key, all recipes showing the pictogram can be used as a jug button. After the choice of drink, the display shows how many cups are made. You can set the number of cups with the +/- button.

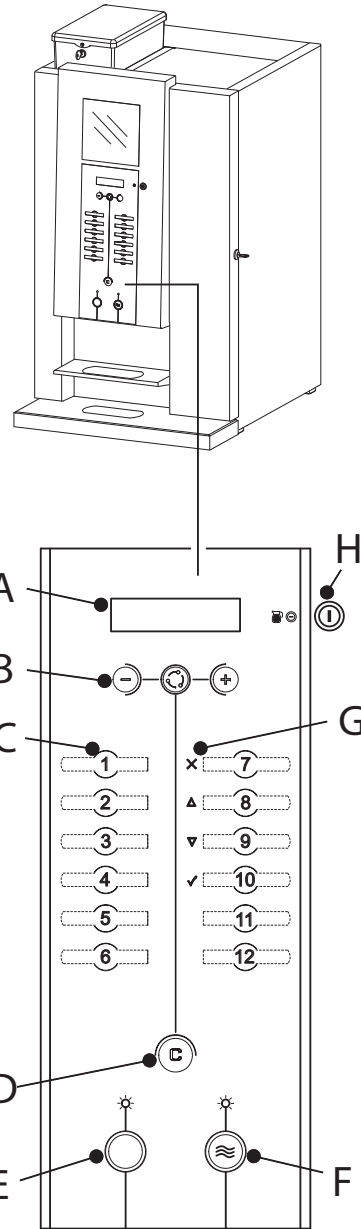

Fig. 22

5.2 Service panel (inside the door)

A. Standby

With this button you can set the device on standby. The selection buttons are turned off and the boiler is kept at 60°C. Display: [Not in use – Standby]. Push this button again to reactivate the machine.

B. Open brewer

With this button you can set the brewer unit in the 'open' position, so that the upper brewer section can be taken out for cleaning. See chapter 8.5 **Cleaning the brewer section**. Push this button again to close the brewer unit.

C. Mixer(s) rinsing programme

With this button the rinsing programme for the mixer(s) will be started. For detailed instructions, see chapter 8.4 **Cleaning the mixer unit**.

D. Operator menu button

With this button the Operator menu appears on the display. See chapter 6.1 **Operator menu**. Press this button again to leave the Operator menu.

E. Brewer rinsing programme

With this button you start the rinsing programme for cleaning the brewer. For detailed instructions, please see chapter 8.3 **Cleaning the brewer unit**.

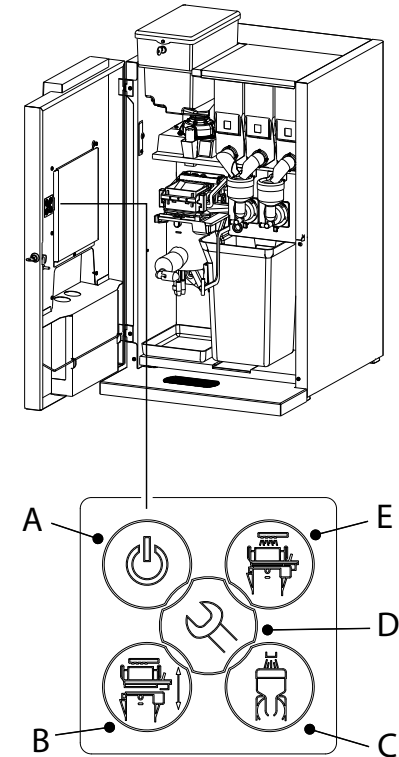
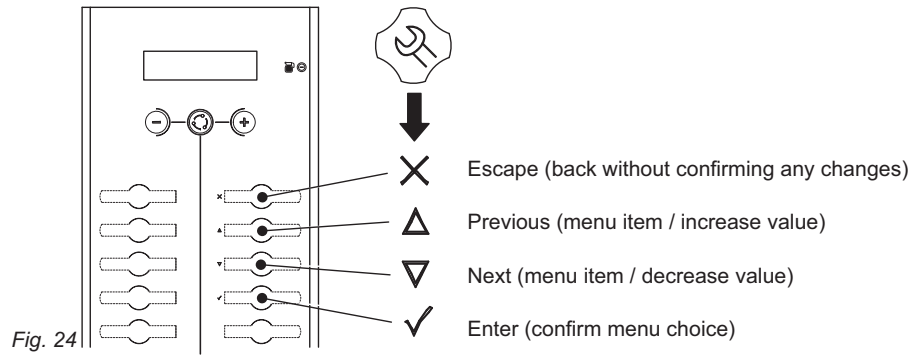

Fig. 23

6. MENU STRUCTURE

6.1 The operator menu



Operator menu structure Range Factory setting

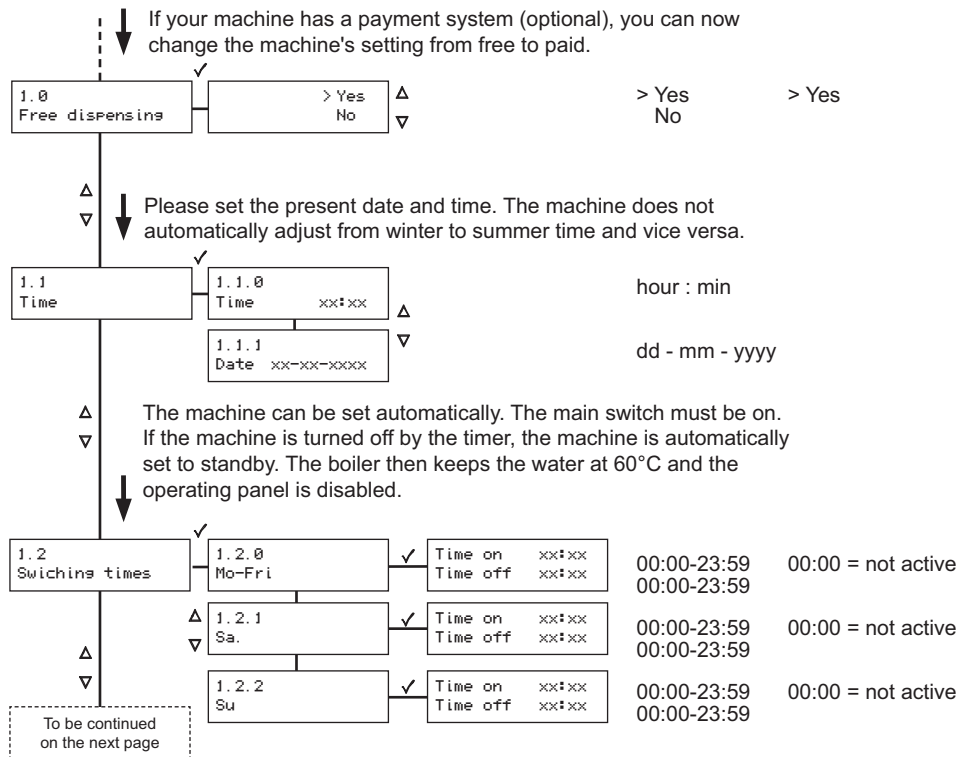

Operator menu structure Range Factory settings

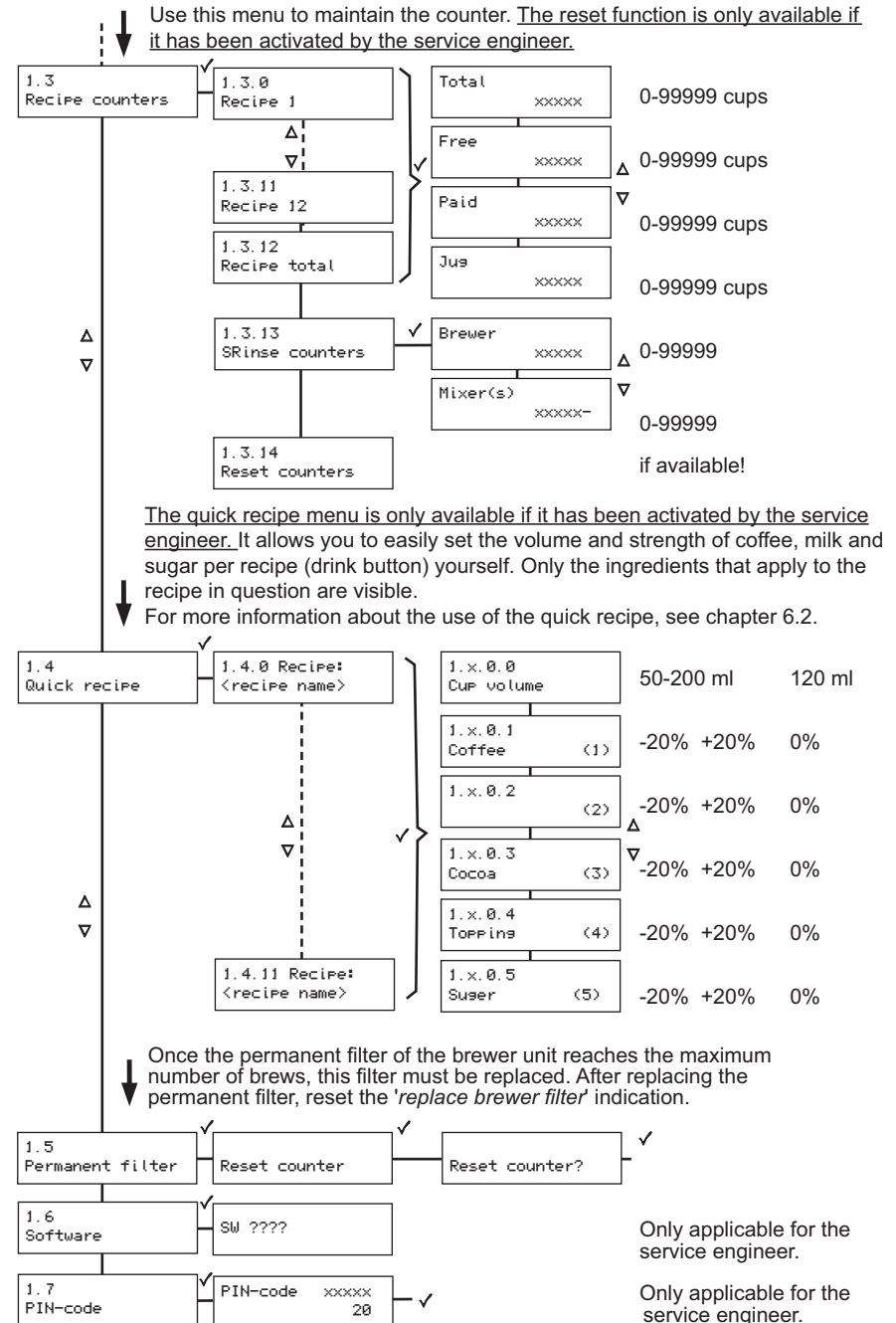

6.2 Quick recipe

With the quick recipe (fig. 25) you can easily adjust the volume and the strength of the used ingredients such as coffee, milk (topping), cocoa and/or sugar for each drink (recipe).

- The quick recipe menu is only available if it has been activated by the service engineer.
- Only the ingredients that are relevant for the recipe in question are shown.

The example below shows how you can increase the **volume** and quantity of **milk** in the recipe for **coffee Milk & Sugar**.

 If the **volume** is increased, the **coffee strength** is automatically proportionately adjusted. Ingredients such as **topping** and **sugar** are also adjusted automatically.

If after you set the volume, you are not satisfied with the strength of the coffee, you can adjust the quantity of ground coffee. Of course, other ingredients like topping and sugar can also be adjusted separately.

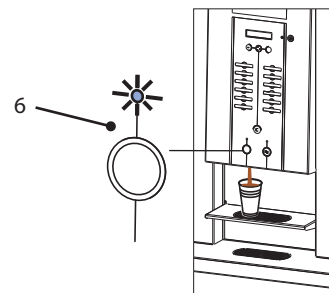
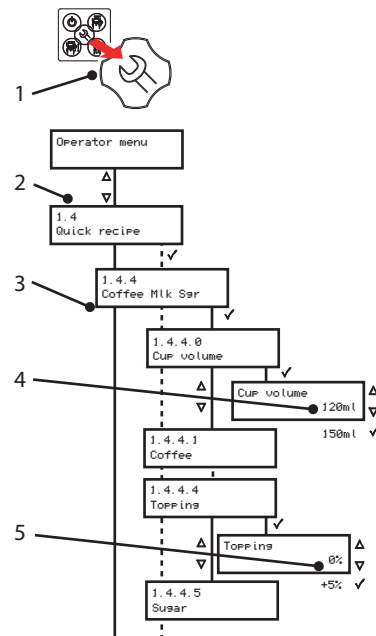

Fig. 25

1. Open the operator menu (fig. 25)
2. Go to 1.4 **Quick recipe** and press enter.
3. Go to the recipe you wish to change **Recipe: Coffee Milk Sgr** and press enter twice.
4. The display shows the set volume. Change the volume to 150 ml and press enter to accept the new setting.
5. Go to **Strength: Topping** and press enter. Increase the dosage of milk by 5% and press enter to accept the new setting.
6. **TESTING:** after the volume and/or strength ingredient has been adjusted, a blue LED starts flashing next to one of the dispensing buttons. Place a cup under the outlet in question and press the relevant dispensing button. Your drink is now prepared according to the changed settings.
7. Assess the drink's volume and taste. Repeat these actions for this drink or other drinks if necessary.

7. DAILY USE

7.1 Filling (up) the canisters

Never fill the ingredient canisters with more than what is required for one day in order to ensure that the products remain fresh at all times!

Coffee bean canister

1. Open the bean canister (fig. 26) with the key.
2. Fill the canister with coffee beans.
3. Close the canister again.

 Fill the transparent canister only with **coffee beans!**

Instant canisters

Always ensure that the transport auger is covered in approx. 3 cm of ingredient. Shake canister(s) containing plenty of product to prevent the contents from 'caving in'.

To fill up the canisters, you must remove them from the device.

1. Take the canister(s) from the device by pulling it/ them towards you (fig. 27).

2. Fill the canister(s) with the appropriate product.

 Fill the canisters with instant products such as topping, cocoa (see table 1 on page 62).

3. Place the canister(s) back into the machine in the right order. Make sure that the drive mechanism of the canister falls over the cog in the back wall and that the fastening ridge goes into the hole of the plate (fig. 28).

4. Turn the dispensing outlet(s) back to their correct position (fig. 29).

- Make sure that the correct canister is placed in its rightful place (see numbers on the canister and the device).
- Rinse off any product that was spilled in the mixer(s) by using the cleaning programme.

7.2 Preparations

1. Turn on the device by using the main switch. The display lights up.
2. Close the door and lock it.
3. The device is filled [*Boiler filling*] and then starts heating the water [*Boiler Heating*].
4. If necessary, fill up the canister(s) when the boiler is heating up.
5. Once the device has warmed up, the display shows [*Make your choice*].
6. Place an empty collection tray under the outlet and carry out the brewer and mixer rinsing programme.
7. The device is now ready for use.

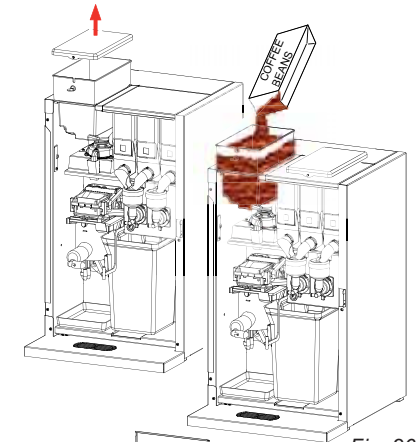

Fig. 26

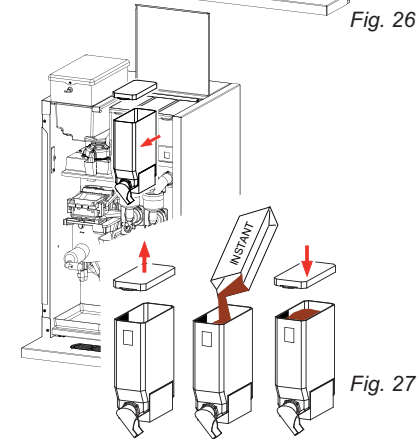

Fig. 27

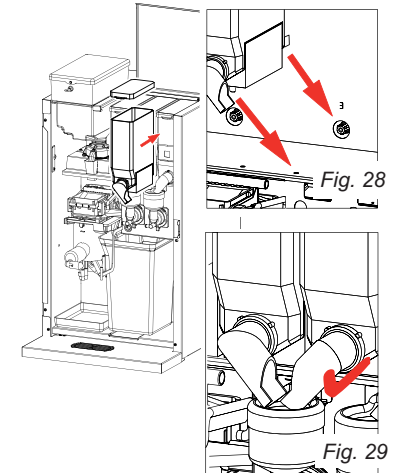

Fig. 29

7.3 Dispensing cups/goblets

The machine has separate dispensing points for hot drinks and water (fig. 30).

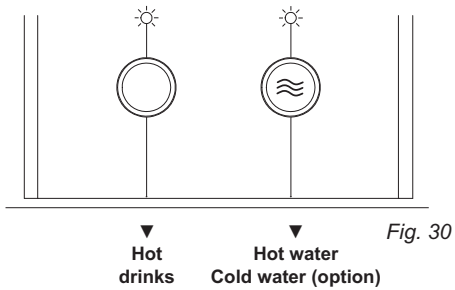

Fig. 30

See fig. 31:

1. Select your drink.
2. The blue LED above the dispensing point starts flashing.
3. Place your cup and press the dispensing button.
4. Your drink is prepared.

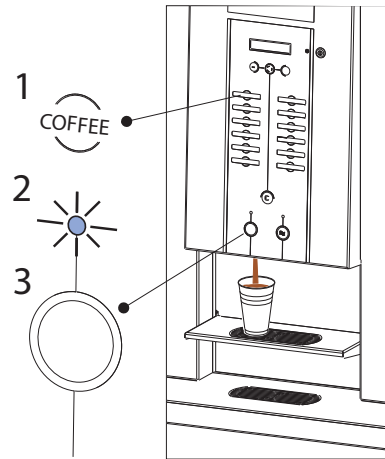

Fig. 31

7.3.1 Strength adjustment

The machine has strength adjustment.

See fig. 32:

1. Select your drink.
2. The blue LED above the dispensing point starts flashing.
3. Coffee strength adjustment?
Press the 'Set' button (⊖) and set the strength using the +/- buttons.
4. Place your cup and press the dispensing button.
5. Your drink is prepared.

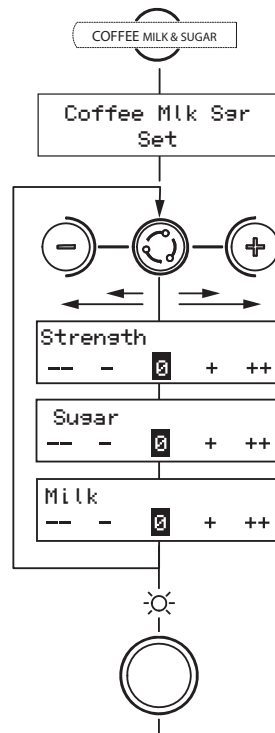

Fig. 32

7.4 Dispensing jugs

The machine can fill small thermos jugs. To do this, turn up the cup tray.

Only persons who have the key of the jug lock can use the jug function. See fig. 33.

1. Turn the jug lock to the right.
2. Select your drink.
3. The blue LED above the dispensing point starts flashing.
4. Place a thermos jug under the dispensing point and press the dispensing button.
5. Your drink is prepared.

Attention: coffee preparation progress is indicated on the display. The coffee is made and poured into the jug per cup.

6. When you are finished, turn back the jug lock and retrieve the key.

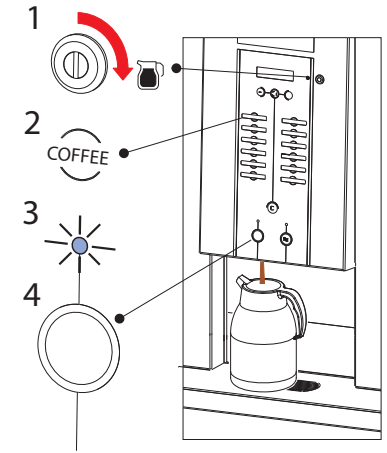

Fig. 33

Attention: Only buttons with this (⊖) pictogram are pre-programmed for jugs. Drink buttons without this pictogram cannot be used for jugs. Please consult your dealer for any deviating button settings.

Emergency stop jug: The dosing of a jug can be stopped by simply pushing the **correction/ stop button C**. After pushing this button, the chosen jug recipe is cancelled and only one cup is dispensed.

7.4.1 Jug volume

The machine can adjust the jug volume. See fig. 34.

1. Turn the jug lock to the right.
2. Select your drink.
3. The blue LED above the dispensing point starts flashing.
4. The display indicates the number of cups to be made. Volume adjustment? Use the +/- buttons to increase or decrease the number of cups.

Attention: if the number of cups is set too high, the jug will overflow! Coffee strength adjustment?

Press the 'Set' button (⊖) and use the +/- buttons to set the desired strength.

5. Place a thermos jug under the dispensing point and press the dispensing button.
6. Your drink is prepared.
7. When you are finished, turn back the jug lock and retrieve the key.

Attention: the jug volume adjustment function will not work if the machine is set to paid dispensing.

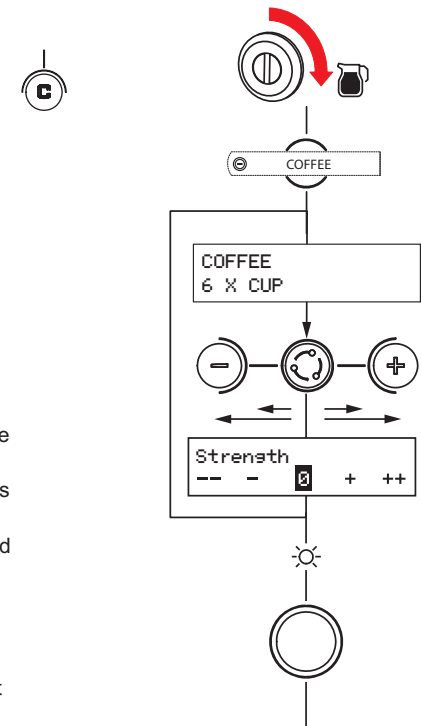

Fig. 34

7.5 Payment systems (optional)

7.5.1 Coin system

Major parts (fig. 35):

1. Coin acceptor slot
2. Returns button
3. Money return slot
4. Money tray
5. Door lock is also money tray lock

Set to free

1. Open the operator menu (see chapter 6).
2. Go to **1.0 Free vend.**
3. Change No into Yes and confirm your choice.
4. The machine is now set to free dispensing.
[Make your choice]

Set to paid

1. Open the operator menu (see chapter 6).
2. Go to **1.0 Free vend.**
3. Change Yes into No and confirm your choice.
4. The machine is now set to paid dispensing.
[Make your choice and insert money]

Use payment system

See fig. 36

1. Select your drink. The display shows the price of your drink on the left and the inserted amount on the right

Coffee mlk s&r	Cr. 0,00
0,50	

right (Cr.).

2. Insert the exact amount.
3. If sufficient money is inserted (Cr.), the blue LED above the dispensing point starts flashing.
4. If desired, use the strength adjustment (see chapter 7.3.1).
5. Place your cup on the tray and press the dispensing button.
6. Your drink is prepared.

For setting / changing product prices, see chapter 2.3 Service menu in the service appendix or contact your dealer.

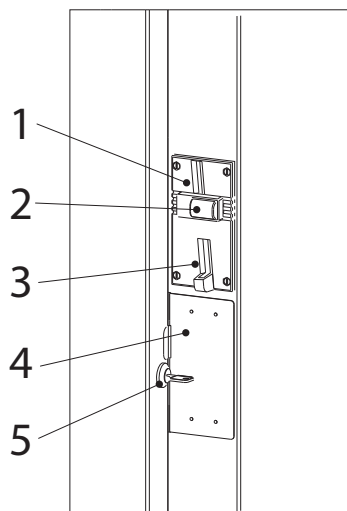

Fig. 35

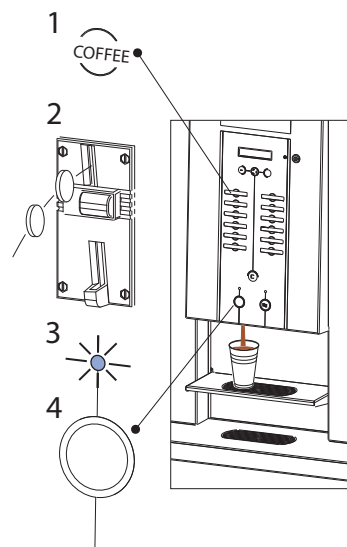

Fig. 36

7.5.2 Coin changer

The OptiFresh is available with an optional coin changer suitable for euros (€0.05 - €2.00). Other currencies are available on request.

The coin changer has 6 coin tubes (€ 0.05 / 2x 0.10 / 0.20 / 0.50 / 1,00).

Major parts (fig. 37):

1. Return button
2. Coin insert
3. Lock
4. Change

Set to free

1. Open the operator menu (see chapter 6).
2. Go to **1.0 Free vend.**
3. Change No into Yes and confirm your choice.
4. The machine is now set to free dispensing.
[Make your choice]

Set to paid

1. Open the operator menu (see chapter 6).
2. Go to **1.0 Free vend.**
3. Change Yes into No and confirm your choice.
4. The machine is now set to paid dispensing.
[Make your choice and insert money]

 If the coin changer does not have enough money available, the display shows the following message: [Make your choice and insert exact money]

Using paid vending

See fig. 38

1. Place a cup (select the desired drink if price is unknown). The display shows the price of your drink on the left and the inserted amount on the right (Cr.).

Coffee mlk s&r	Cr. 0,00
0,50	

2. Insert the money.
3. If sufficient money is inserted (Cr.), the blue LED above the dispensing point starts flashing.
If desired, use the strength adjustment (see chapter 7.3.1).
4. Place your cup on the tray and press the dispensing button.
5. Your drink is prepared and change will return.

For setting / changing product prices, see chapter 2.3 Service menu in the service book or contact your dealer.

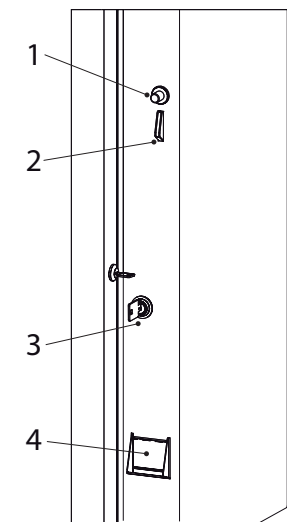

Fig. 37

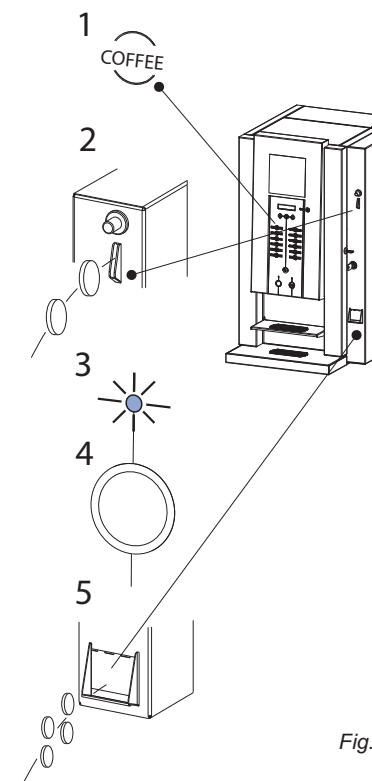

Fig. 38

7.6 Automatic disabling functions

During use, the following display messages (fig. 39) can appear and automatically disable the drink selection buttons:

- Boiler filling up;** Water pressure is gone or the water tank (stand-alone setup) is empty.
- Boiler heating up;** The boiler temperature is (temporarily) too low because of too much water consumption. As soon as the temperature is fine, the message automatically disappears and the drink selection buttons will work again.
- Drip tray is full;** Once the drip tray is emptied, the message automatically disappears and the drink selection buttons will work again.
- Waste bin is full;** The maximum amount of cups of coffee to be made that fits the waste bin has been reached. Empty waste bin. The cup counter automatically resets as you replace the tray.
- Waste bin missing;** The waste bin cannot be detected. Check the waste bin.
- Door open;** For safety reasons the machine is automatically switched off as soon as the door is opened. The machine can be switched on with the door open by using the door pen (see chapter 8.1).
- Standby;** The machine is set to standby. This function could have been set manually (see chapter 5.2-A) or automatically (see chapter 6.1 Operator menu item 1.2 Timer settings).

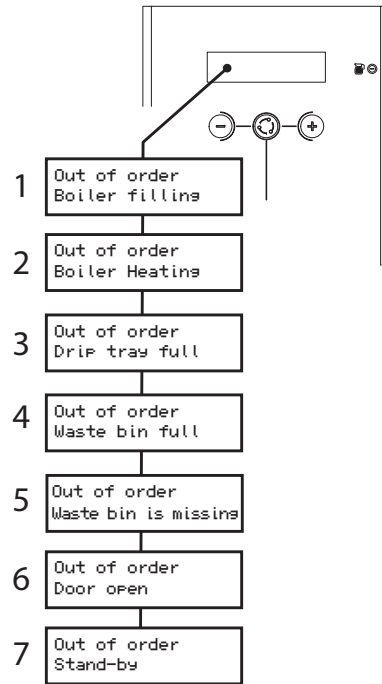

Fig. 39

7.7 Display messages during use

The following display messages (fig. 40) can appear immediately after the machine is switched on:

- Rinse brewer;** The brewer unit must be cleaned. Text message when: brewer NOT cleaned after 300 coffee's or 5 day's.
See chapter 8.3.1 **Cleaning the brewer unit**. Once the cleaning programme has been carried out, this display message disappears.
- Replace brewer filter;** The brewer filter (or permanent filter) has reached the maximum number of brews and should be replaced as a precaution.
See chapter 8.7.1 How to replace the brew filter and how to erase the display message.
- Descaling / filter;** The machine must be descaled or the water filter must be replaced. Contact your dealer for technical maintenance.

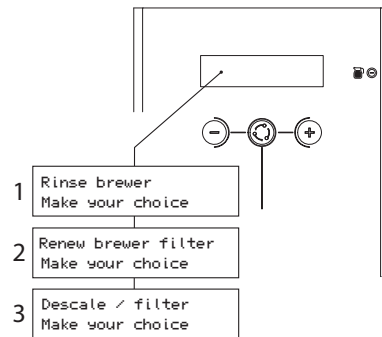

Fig. 40

8. MAINTENANCE

⚠ WARNING

- The device must not be submerged or hosed down.
- Do not leave the device during maintenance.

You can follow the HACCP hygiene code instructions of your organisation for the use of cleaning products. Look or search under object: Machine of hot drinks.

- ☞ Don't give bacteria a chance: maintain your device according to regulations!

8.1 Door switch

⚠ WARNING

- Take into account the brewer's moving parts when the machine is in use with the service pin.
- The brewer motor is extremely powerful and can jam hands or fingers!

The machine has a door switch that turns the machine off when the door is opened.

[Out of order. Door open]

The machine can be turned on with the door open (for example for cleaning activities) by inserting the supplied service pin (fig. 41) into the door switch.

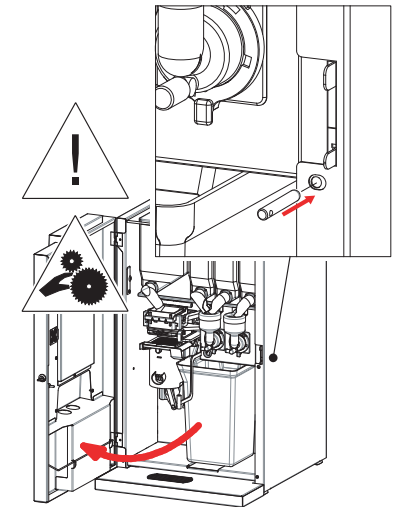

Fig. 41

8.2 Rinsing programmes

The machine has two rinsing programmes for the daily rinsing of the brewer unit (fig. 42-1) and mixer system (fig. 42-2).

- We advise you to run the rinsing programme both at the beginning and at the end of normal office hours.
- The rinsing water must be collected in a rinsing tray below the machine.

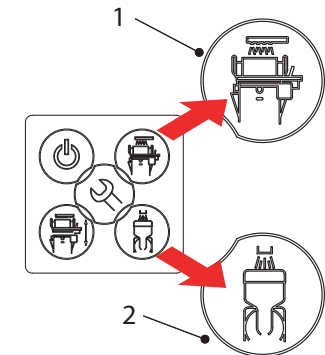

Fig. 42

8.3 Cleaning daily

8.3.1 Cleaning the brewer unit

The brewer is in constant contact with coffee. After some time, a deposit of coffee oils, coffee particles and minerals from the water forms on the brewer's permanent filter. This will reduce the permeability of the filter and therefore increase the chances of the brewer section overflowing.

During the cleaning procedure, the brewer is filled with hot water. After a soaking period, the brewer is rinsed 3 times with hot water.

Duration: approx. 3 min. (rinsing water approx. 800 ml).

Requirements:

- Collection tray of at least 1.5 litres.

In order to clean the brewer:

1. Open the machine door and press the brewer cleaning button (fig. 43-1).
2. Close the door or position the service pin (see chapter 8.1) so that the door can remain open.
3. Follow the instructions shown by the display (fig. 43-3) and use the X and V buttons on the operating panel (fig. 43-2).

Stopping the cleaning cycle?

- The start of the brewer cleaning procedure can be cancelled with the X button or by the C button.
- Increasing the boiler temperature and soaking the brewer can be skipped with the X button or by the C button.
- The rinsing progress (3x) can be interrupted with the X button or by the C button.

8.3.2 Emptying and cleaning the waste bin

Empty the waste bin every time you have filled the fresh brew canister.

Tip: use a well-fitting bin liner (fig. 44) in order to empty and clean the waste bin quickly!

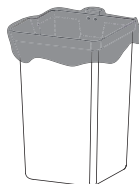

Fig. 44

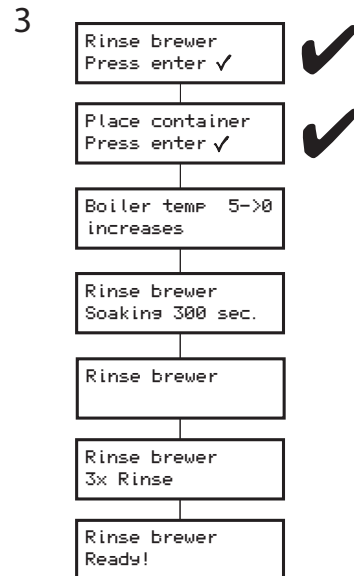
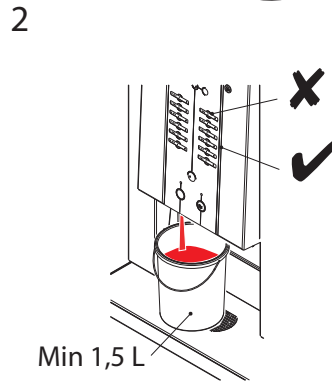
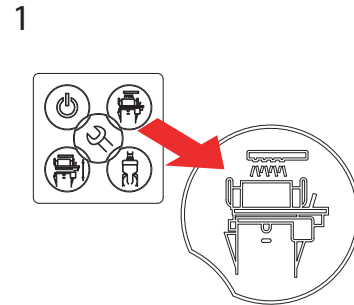

Fig. 43

8.3.3 Cleaning the mixer unit

The mixer casing is in regular contact with the product and must therefore be cleaned thoroughly and regularly.

The mixers are rinsed with hot water 3 x during the cleaning procedure.

Duration: approx. 1 min. (rinsing water approx. 800 ml).

Requirements:

- Collection tray of at least 1.5 litres.

For cleaning the mixer(s);

1. Open the door of the machine and press the mixer cleaning button (fig. 45-1).
2. Close the door and position the service pin (see chapter 8.1) so that the door can remain open.
3. Follow the instructions shown on the display (fig. 45-3) and use the X and V buttons on the operating panel (fig. 45-2).

Stopping the cleaning cycle?

- The start of the mixer cleaning procedure can be cancelled with the X button or by the C button.
- Increasing the boiler temperature and soaking the brewer can be skipped with the X button or by the C button.
- The rinsing process can be interrupted with the X button or by the C button.

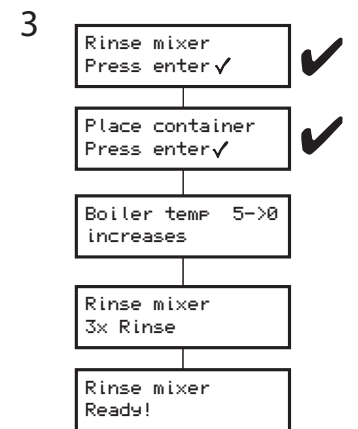
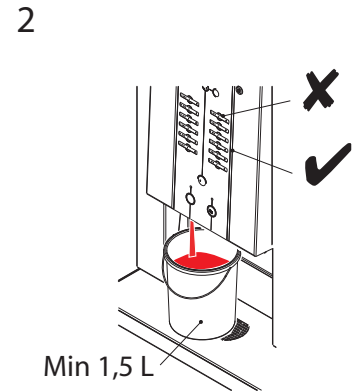
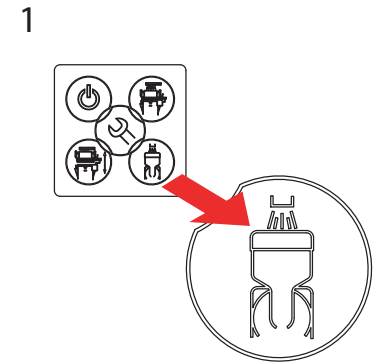

Fig. 45

8.4 Weekly cleaning

8.4.1 Cleaning the brewer filter / brewer chamber

Carry out before the daily cleaning.

Duration: approx. 5 min.

Requirements:

- Permanent filter (cleaned) (Art. No. 03488)
- Filter disassembly tool (Art. No. 03343)

1. Open the door of the machine and press the open/close brewer button. The brewer will turn into the 'open' position.

Close the door or position the service pin (see chapter 8.1) so that the door can remain open.

2. Remove the brewer chamber and coffee outlet.
3. Point the filter disassembly tool up all the way via the brewer outlet.
4. Push the far end of the tool firmly against the **backside** of the permanent filter until it clicks out of the cylinder.

 **Clean permanent filter; see next chapter!**

5. Place a clean (or new) permanent filter into the brewer cylinder. Ensure that the protruding section points backwards. Press the filter until it clicks into the cylinder.
6. Clean*/rinse the brewer chamber and coffee outlet thoroughly.
7. Place the brewer chamber and coffee outlet back on the brewer.

 **CAUTION:** the brewer can be severely damaged if the brewer section is not well **SECURED** when returning it to the machine. Make sure that the wiper is always placed **BETWEEN** both arms!

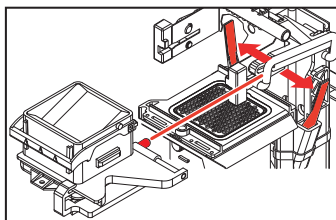

Fig. 46a

8. Press the brewer open/close button. The brewer returns to its initial position. The machine is ready for use again.

* Use a normal detergent.
In case of persistent stains, use our tried and tested coffee fur remover!

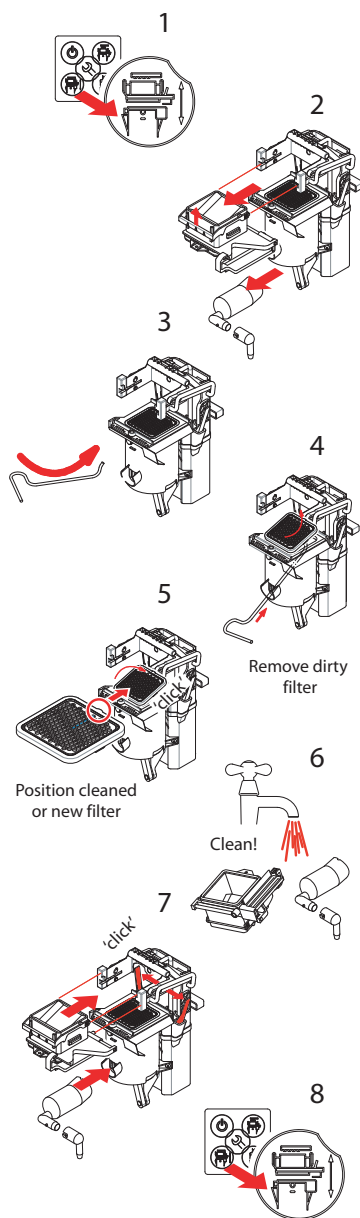



Fig. 46

8.4.2 Brewer filter cleaning

The brewer is in constant contact with coffee. After some time, a deposit of coffee oils, coffee particles and minerals from the water forms on the brewer's permanent filter. This will reduce the permeability of the filter and therefore increase the chances of the brewer chamber overflowing.

 **The brewer filter must be kept in the best possible condition by carrying out the following cleaning procedure.**

First carry out Chapter 8.4.1 Cleaning the brewer filter / brewer chamber!

Requirements:

- Collection tray with the size of the permanent filter
- Brewer filter cleaner (Art. No. 00002)
- Brewer filter * (Art. No. 03488)
- Filter disassembly tool (Art. No. 03343)

* supplied with the machine

1. Make a solution with 1 part brewer filter cleaner and 4 parts lukewarm water.
2. Soak the brewer filter for approx. 8-12 hours (overnight) in the brewer filter cleaner.
3. Rinse the brewer filter thoroughly over the entire surface.

8.4.3 Replacing the brewer filter

The machine can indicate that the brewer filter needs replacement.

If the display shows *Renew brewer filter* (fig. 48), both filters made 20.000 cups of coffee and must be replaced as a precaution.

1. Follow the instructions of chapter 8.4.1 for replacing the filter screen.
2. Reset the display after placing the new permanent filter. Go to **1.5 Permanent filter** of the operator menu and reset the counter.

 Art. No. permanent filter 03488

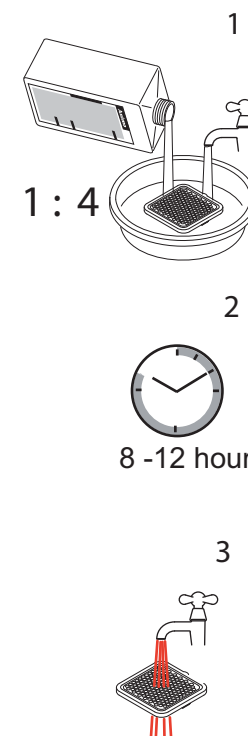

Fig. 47

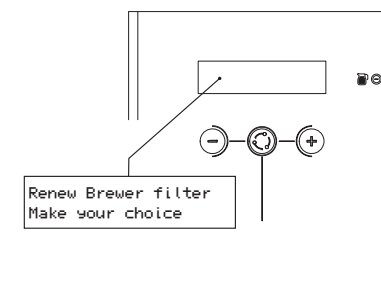
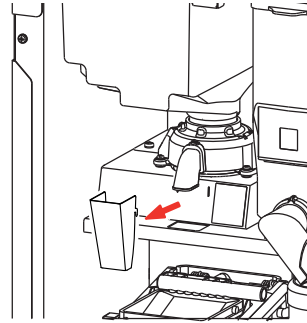

Fig. 48

8.4.4 Cleaning the coffee grinder

Weekly clean the coffee outlet by removing it from the grinder.

The grinder can only be cleaned by your dealer. This is combined with half yearly maintenance.



8.4.5 Removing the entire brewer

The brewer can be entirely removed for thorough cleaning.

Removing the brewer (fig. 49):

1. Open the door of the machine and press the open/close brewer button. The brewer will turn into the 'open' position.

Close the door or position the service pin (see chapter 8.1) so that the door can remain open.

Then remove the service pin so that the brewer can be safely removed.

2. Flip up the hot water machine arm.
3. Remove the coffee outlet from the brewer.
4. Remove the waste bin.
5. Remove the water connection.
6. First pull the bottom section of the brewer towards you to release it from the drive mechanism.
7. Lift the brewer from the suspension bracket.
8. The brewer can now be thoroughly cleaned.
9. Position the parts back into the machine in reverse order. Caution: first secure the brewer into the suspension bracket and then press the bottom section back into the drive mechanism. **Do not forget to reconnect the water supply (5)!**
10. Press the open/close brewer button. The brewer will return to its initial position. The machine is ready for use again.

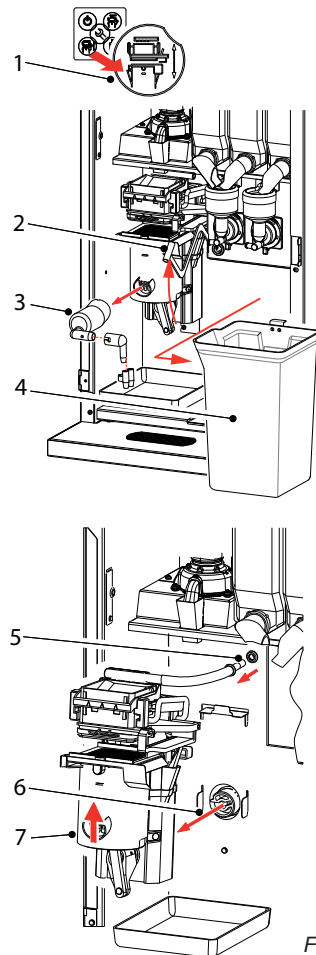

Fig. 49

8.4.6 Cleaning the mixer unit

The mixer casing is in regular contact with the product and must therefore be cleaned thoroughly and regularly.

If the machine is used very frequently, carry out this cleaning procedure up to a few times a week!

Duration: approx. 5 min.

Requirements:

- Normal detergent / coffee deposit remover
- Rinsing facility
- Tea towel
- Hygiene set (for quick cleaning)

Cleaning mixer(s) (fig. 50):

1. Remove the tubes between the mixer(s) and the outlet. Remove the ingredient canisters from the device (turn the dispensing elements up so that no ingredients fall out).
2. Turn the green mounting ring to the right and remove the mixer casing by pulling it towards you.
3. Pull the mixer fan towards you to remove it from the mixer axis and remove the green mounting ring.
4. Clean the removed parts in warm water with a normal detergent.
5. Fit the parts in the opposite order.

CAUTION: ensure that the arrow on the mixer fan points towards the flat side of the axis and push the mixer fan over the axis until you hear a clear 'click' (don't push it too far down!).

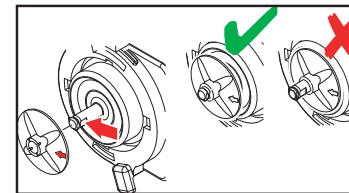

Fig. 50a

6. Place the mixer case back onto the mixer. Turn the green mounting ring to the left.
7. Secure the tubes between the mixer(s) and the outlet. Place the canisters back and turn the dispensing elements back into the correct position.

Switch the device back on and try a few test drinks to check the correct operation.

- * Use a normal detergent.
In case of persistent stains, use our tried and tested coffee fur remover!

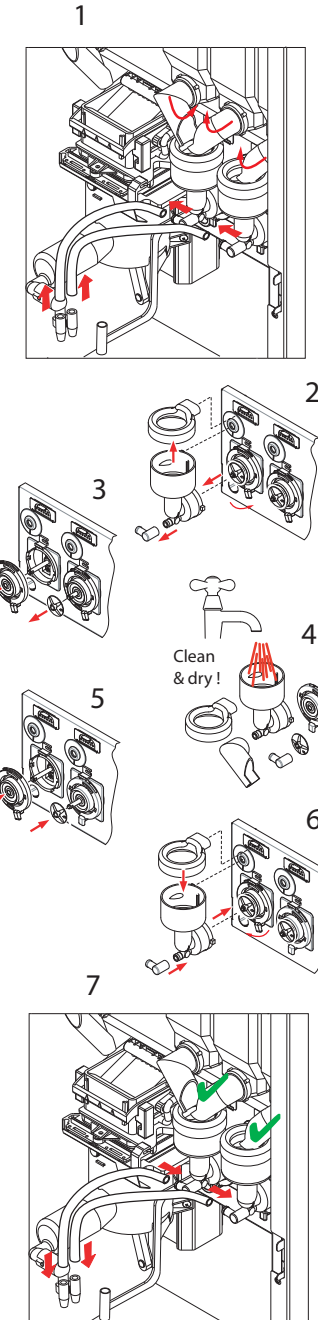



Fig. 50

8.5 Monthly cleaning

8.5.1. Cleaning the brewer unit

The brewer is in constant contact with coffee. After some time, a deposit of coffee oils, coffee particles and minerals from the water forms on the brewer's permanent filter.

 **The brewer filter must be kept in the best possible condition by carrying out the following cleaning procedure.**

During the cleaning procedure, the brewer is filled with hot water. After a soaking period, the brewer is rinsed 3 times with hot water.

Duration: approx. 8 min. (rinsing water approx. 800 ml).

Requirements:

- Collection tray of at least 1.5 litres.
- Sachet of coffee deposit remover (Art.No. 49009)

In order to clean the brewer:

1. Open the machine door and press the brewer cleaning button (fig. 51-1).
2. Fill the brewer section (fig. 51-2) in advance with 1 sachet /1 tea spoon of coffee deposit remover.

 **Attention: if the brewer has been cleaned with detergent, make sure you immediately carry out chapter 8.4.1 Cleaning the brewer chamber / brewer filter.**

3. Close the door or position the service pin (see chapter 8.1) so that the door can remain open.
4. Follow the instructions shown by the display (fig. 51-3) and use the X and V buttons on the operating panel (fig. 51-2).
5. Take two coffees to lubricate the brewer cylinder again.

Stopping the cleaning cycle?

- The start of the brewer cleaning procedure can be cancelled with the X button or by the C button.
- Increasing the boiler temperature and soaking the brewer can be skipped with the X button or by the C button.
- The rinsing progress (3x) can be interrupted with the X button or by the C button.

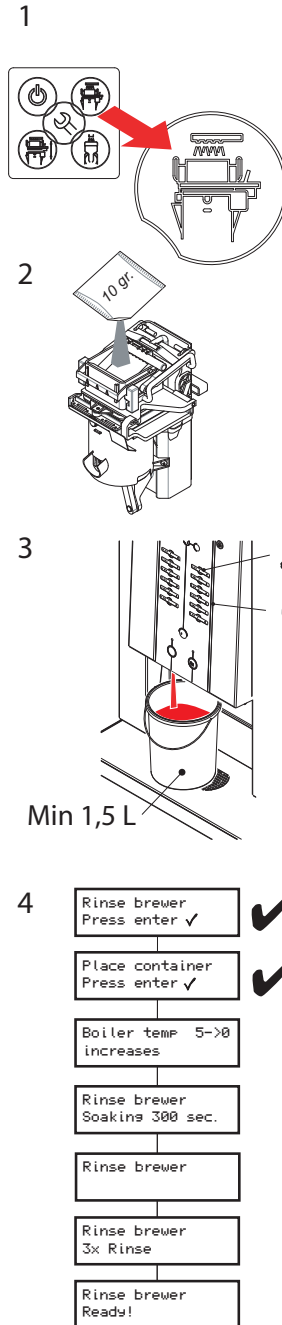

Fig. 51

8.5.2 Cleaning the mixer extraction filter

First carry out chapter 8.4.5 Cleaning the mixer unit (weekly)!

If the machine is used very frequently, carry out this cleaning procedure every week!

Duration: approx. 2 min.

Requirements:

- Normal detergent / coffee fur remover
- Tea towel
- Hygiene set (for quick cleaning)

Cleaning brewer filter (fig. 52):

1. Turn the green mounting ring right and remove the mixer case from the mixer by pulling it towards you.
2. Pull the extraction filter(s) from the machine.
3. Remove the top plate and the blue filter.
4. Clean* and dry the filter or use a clean filter from the hygiene set.
5. Place the filter back in its position and reapply the top plate.
6. Put the extraction filter(s) back in place.
7. Place the mixer case back on to the mixer. Turn the green mounting ring to the left.
8. Secure the tubes between the mixer(s) and the outlet.

Turn the device back on and try a few test drinks to check correct operation.

- * Use a normal detergent.
In case of very persistent stains use our coffee fur remover!

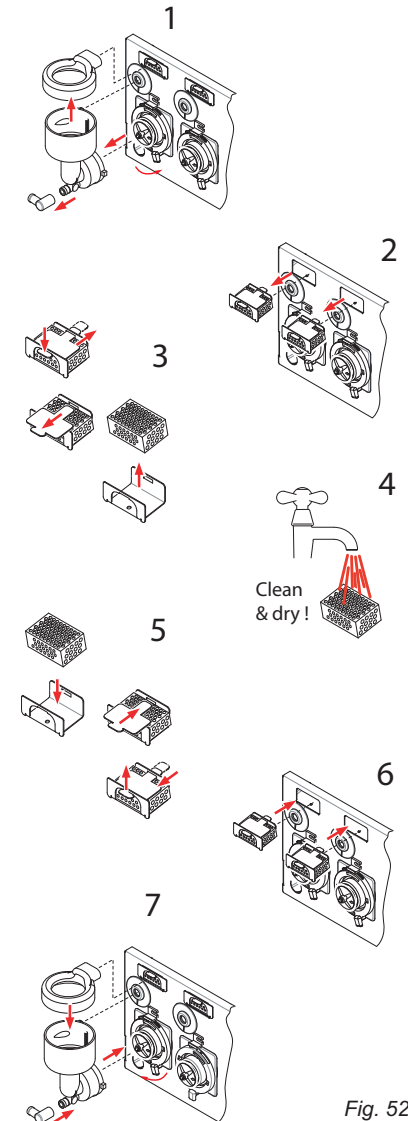

Fig. 52

8.6 Cleaning the canister(s)

8.6.1 Instant canister(s)

Daily: Clean the dispensing opening (fig. 53-1) and the dispensing element (fig. 53-2) with a dry dusting brush.

Weekly: Empty and clean the ingredient canister(s) with a dry dusting brush. Remove any caked residue.

Monthly: Empty and wash the ingredient canister(s) with a mild detergent.

 The canisters are dishwasher-safe.

If necessary the transport auger (fig. 54-2) can be removed by unscrewing the front (fig. 54-3) and back swivel (fig. 54-1). The entire auger can then be removed.

 Pay attention when fitting the dispensing opening of the instant canister (fig. 54-4). The opening must be pointed upwards.

- Make sure you keep every transport augers with its own canister during reassembly.
- Ensure the canisters are COMPLETELY dry before refilling them.

8.6.2 Bean canister

Monthly bean canister empty and wash with a mild detergent.

 The beans canister must not be washed in the dishwasher.

1. Slide down the bean stopper (fig 55-1).
2. Lift the canister from the coffee grinder and empty it. (Fig. 55-2).
3. Clean the canister and lid with a mild detergent.
4. Before placing the canister back dry it VERY well!
5. Place the canister back on the coffee grinder (Fig. 55-3)
6. Slide up the bean stopper so the canister will be fixated again (Fig. 55-4).
7. Fill the canister with fresh coffee beans.

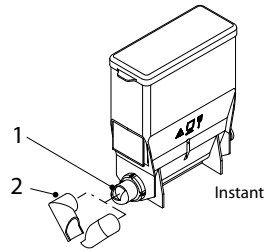

Fig. 53

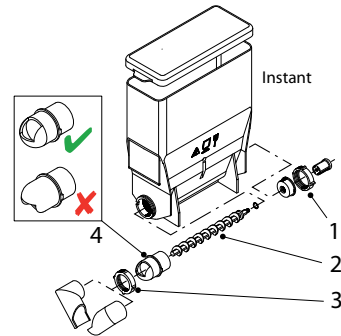

Fig. 54

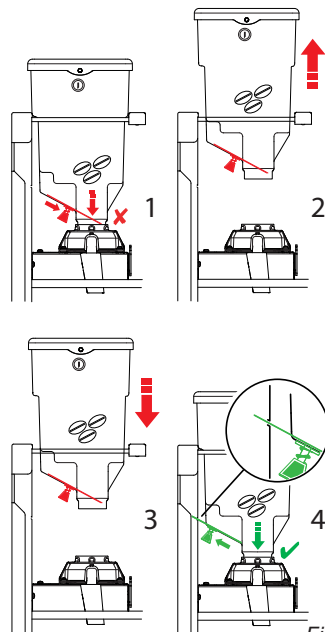



Fig. 55

8.7 Other maintenance

Casing

Clean and dry the stainless steel exterior with a clean damp cloth every day.

Do not use any abrasives as this can cause scratches or dull areas.

 Do not use chlorine or chlorinated detergent as this will damage the stainless steel.

Drip tray and cup tray

The drip tray and grid should be emptied, cleaned with a clean damp cloth and dried every day. Clean the drip tray and grid in hot water every week.

 The drip tray has a safety feature with an electronic sensor that switches the device off when the maximum level is exceeded.

Interior

The inside of the door and the bottom plate must be cleaned with a damp cloth and dried every day.

Empty and rinse the waste bin every day.

 Use a well-fitting bin liner to make emptying and cleaning of the waste bin easier!

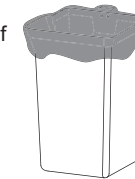

Fig. 56a

Canister compartment

The canister compartment should be cleaned with a clean damp cloth and dried every week.

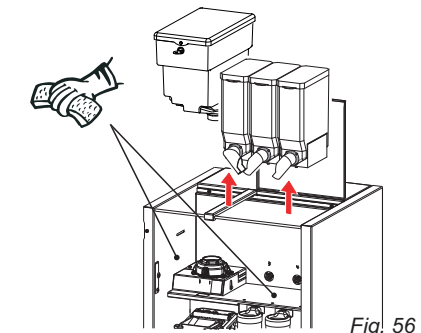
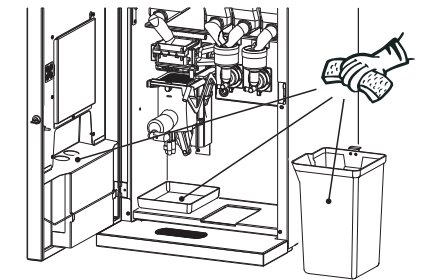
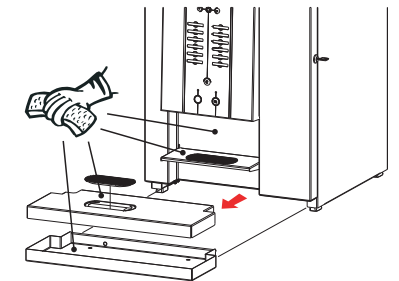
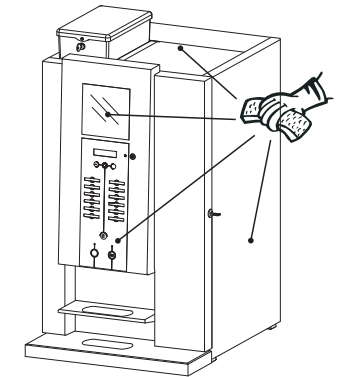

Fig. 56

⚠ WARNING

- In order to descale the water reservoir, the device must be opened. This will expose live parts of the machine, which can be touched easily. This can lead to highly dangerous situations!

⚠ WARNING

- The device must not be submerged or hosed down.
- Always stay with the device during maintenance work.

9. SETTING THE SERVICE MOMENT

During the installation of the device, your service engineer set a time for the device to be serviced.

 The dispensed drinks are counted during use. If the set time for service is reached, the display shows the following message: *Descal / filter* (fig. 57).

When this message appears, you can continue to use the device as usual.

The message indicates that the device must be descaled. If a water filter was fitted (advised), this is also an indication that the filter must be replaced.

For safety reasons, users are not advised to descale the machine and/or replace the filter. We advise you to have an authorised service engineer descale and maintain the device.

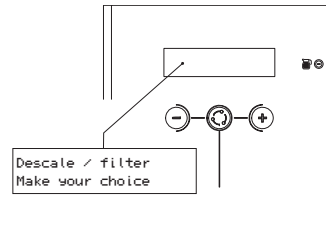

Fig. 57

Water hardness table

Water Quality	Hardness					Limescale Indicator ...cups
	°D	°F	°C	mmol/l	mgCaCo3/l	
Very hard	18-30	32-55	11-18	3,2-5,3	321- 536	5000
Hard	12-18	22-32	7-18	2,2-3,2	214-321	8500
Average	8-12	15-22	5-7	1,4-2,2	268-214	12.500*
Soft	4-8	7-15	2-5	0,7-1,4	72-268	20.500
Very soft	0-4	0-7	0-2	0- 0,7	0-72	0 = off

Table 3

10. DRY BOIL PROTECTION

The device has a dry boil protection that is accessible from the outside. It is located at the back of the device (fig. 58). The dry boil protection turns off the heating element if the temperature is too high. This is usually caused by not descaling the device in time. If the appliance is no longer heating the water, please do the following:

1. Allow the device to cool down.
2. Remove the black protective knob (fig. 58-2).
3. Now press the visible button (fig. 58-1) and push the protective knob back into place.

If the safety device turned off the machine and the message [*Descal / filter*] is visible when restarting the machine, then have the machine descaled. See chapter **9. Setting the service moment**.

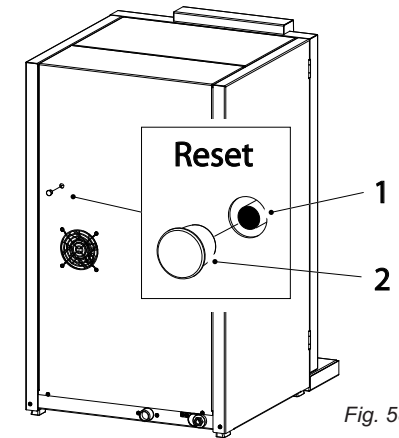

Fig. 58

11. TRANSPORT / STORAGE

Please do the following before transporting or putting the device in storage.

1. Carry out the brewer and mixer unit cleaning programme.
2. Clean the ingredient canister(s), mixer system, leaking tray and casing as described in chapter **8. Maintenance**.
3. Switch off the device and remove the plug from the wall socket.
4. Close the water supply tap and disconnect the water connection tube.
5. Drain the water reservoir (approx. 3 litres) by using the draining tube (Fig. 59-1).
6. Put the parts mentioned in point 5 back in their place.
7. The device is now ready for transport.
8. Before reinstalling the device, please ensure chapter 3. Installation is followed.

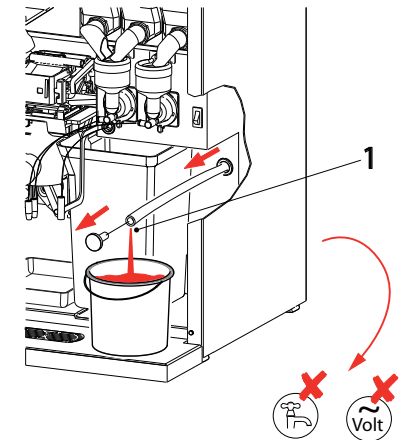

Fig. 59











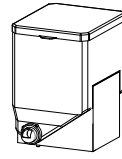



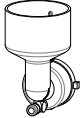

12. TROUBLESHOOTING

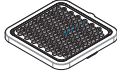
Display messages and errors	Possible cause	Action
Out of order Boiler filling	When used for the first time: boiler is still empty and is being filled.	No action required. When boiler achieves the appropriate level, the display will show 'Boiler is heating up'.
	During use: boiler is not filling up or is filling up too slowly. After 60 sec. the display will show 'E3 Level error'.	Check the water pressure, turn the water supply tap completely open, check the connection tube for any kinks.
Out of order Boiler heating	The boiler temperature is (temporarily) too low because too much water has been used.	Once the temperature is fine, the message automatically disappears and the drink selection buttons are enabled again.
Out of order Drip tray full	Drip tray full.	Once the drip tray is emptied, the message automatically disappears and the drink selection buttons are enabled again.
Out of order Waste bin full	The maximum number of cups of coffee fitting into the waste bin has been reached.	Empty waste bin. The cup counter is automatically reset as the waste bin is put back in its place.
Out of order Waste bin is missing	Waste bin is not being detected.	Check the waste bin.
Out of order Door open	For safety reasons, the machine is switched off when the door is opened.	The machine can be switched on with the door open by using the door pin (see chapter 8).
Out of order Stand-by	The machine is on stand-by.	This function can be set manually (see chapter 5.2-A) or automatically (see chapter 6.1 menu item 1.2 Timer settings).
E1 Level error	Sensor level problem.	Call your dealer or service engineer.
E2 Level error	Boiler is filling up too slowly. There is no water pressure or the water tank (standalone setup) is empty.	Check the water pressure, turn the water supply tap completely open, check the connection tube for any kinks. Turn the device off and on again.
E3 Level error	Boiler is not filling up.	Check the water pressure, turn the water supply tap completely open, check the connection tube for any kinks. Turn the device off and on again.
E4 Brewer error.	Brewer was not started from its initial position.	Check whether the brewer was correctly placed into its bracket. Turn the device off and on again.
E5 Brewer error	Brewer was not returned to its initial position.	Check the brewer.
E6 Boiler temp	Temperature sensor problem.	Call your dealer or service engineer.

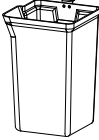
Display messages and errors	Possible cause	Action
E7 BM error	Brewer overload.	The brewer is stuck or fitted incorrectly. Remove the brewer from the machine. See chapter 8.7.2 Remove the entire brewer. Switch the device off and on again.
E8 Mixer 2 error	Mixer 2 overload.	Mixer 2 is unclean or incorrectly fitted. Clean and/or check whether the rotor can run freely. Switch the device off and on again.
E9 Mixer 3 error	Mixer 3 overload.	Mixer 3 is unclean or incorrectly fitted. Clean and/or check whether the rotor can run freely. Switch the device off and on again.
E10 Valve error	Valve overload.	Call your dealer or service engineer.
E11 Ingr. m. error	Ingredient prime mover overload.	The prime mover of one of the canisters is not running smoothly. Empty and thoroughly clean the canister(s). See chapter 8.9 Cleaning the canisters. Switch the device off and on again.
E12 Fan error	Fan overload.	Call your dealer or service engineer.
E13 Mixer error	Mixer group overload.	Clean and/or check whether the rotor can run freely. Switch the device off and on again.
E14 Exit error	Ingredient prime mover group overload.	The prime mover of one of the canisters is not running smoothly. Empty and thoroughly clean the canister(s). See chapter 8.9 Cleaning the canisters. Switch the device off and on again.
	Valve group or fan overload.	Call your dealer or service engineer.
Out of order E16 Level error	Boiler level suddenly much too low.	Call your dealer or service engineer.
Out of order E17 MDB error	There is no communication between machine and payment system	Switch the device off and on again. Call your dealer or service engineer.

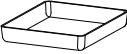
Malfunction	Possible cause	Action
The device does not work.	Fuses (distribution board).	Check fuses.
	Main switch (distribution board).	Check main switch.
	The plug and lead.	Check main cable.
The device does not respond.	The device is in standby.	Switch off stand-by modus.
There are complaints about the products taste.	Canister (almost) empty.	(Re)fill ingredient canister.
	Incorrectly canister position.	Check position.
	Canister outlet blocked.	Clean outlet.
	Canister auger is loose or damp.	Check or clean auger.
	Canister distributor does not work.	Check distributor.
	Wrong ingredient	Check if the right ingredient is used.
	Ingredient is solidified (caked)	Replace ingredient
	Mixer(s) not cleaned/rinsed	Run rinsing programme
	Ingredient expired	Replace ingredient
	Boiler temperature too low	Please warn your supplier
Damp ingredient	Check the ventilation system and replace the ingredient	

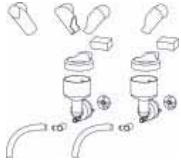
13. ORDERING CONSUMABLES AND ACCESSORIES

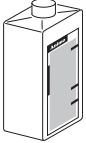
Fresh brew		Instant	
	Decafé		
		03258	03284
			
	07975	03259	03260
	Brewer filter		
		03257	03255
03343	03488		
		03254	03253
07974	08419		
		03326	03256
07976		OptiFresh 2-3	OptiFresh 4
1 KG 100x10gr. Brewer cleaner	0,92 L. Brewer filter cleaner		
		11831	11832
00008 49009	00002		

Afmetingen / Dimensions / Abmessungen / Dimensions

OptiFresh 1, 2 & 3 bean

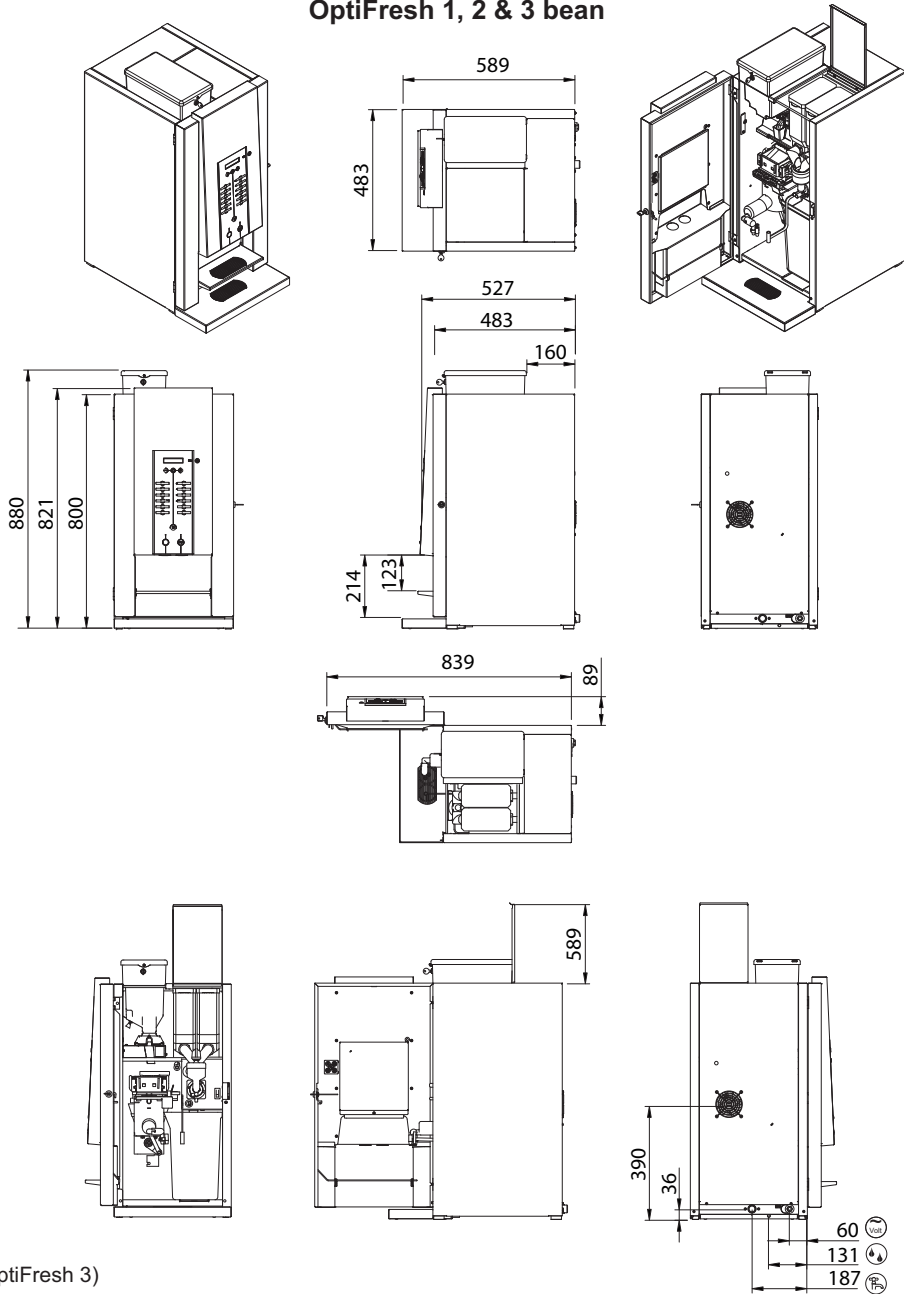

(OptiFresh 3)

Afmetingen / Dimensions / Abmessungen / Dimensions

OptiFresh 4 bean

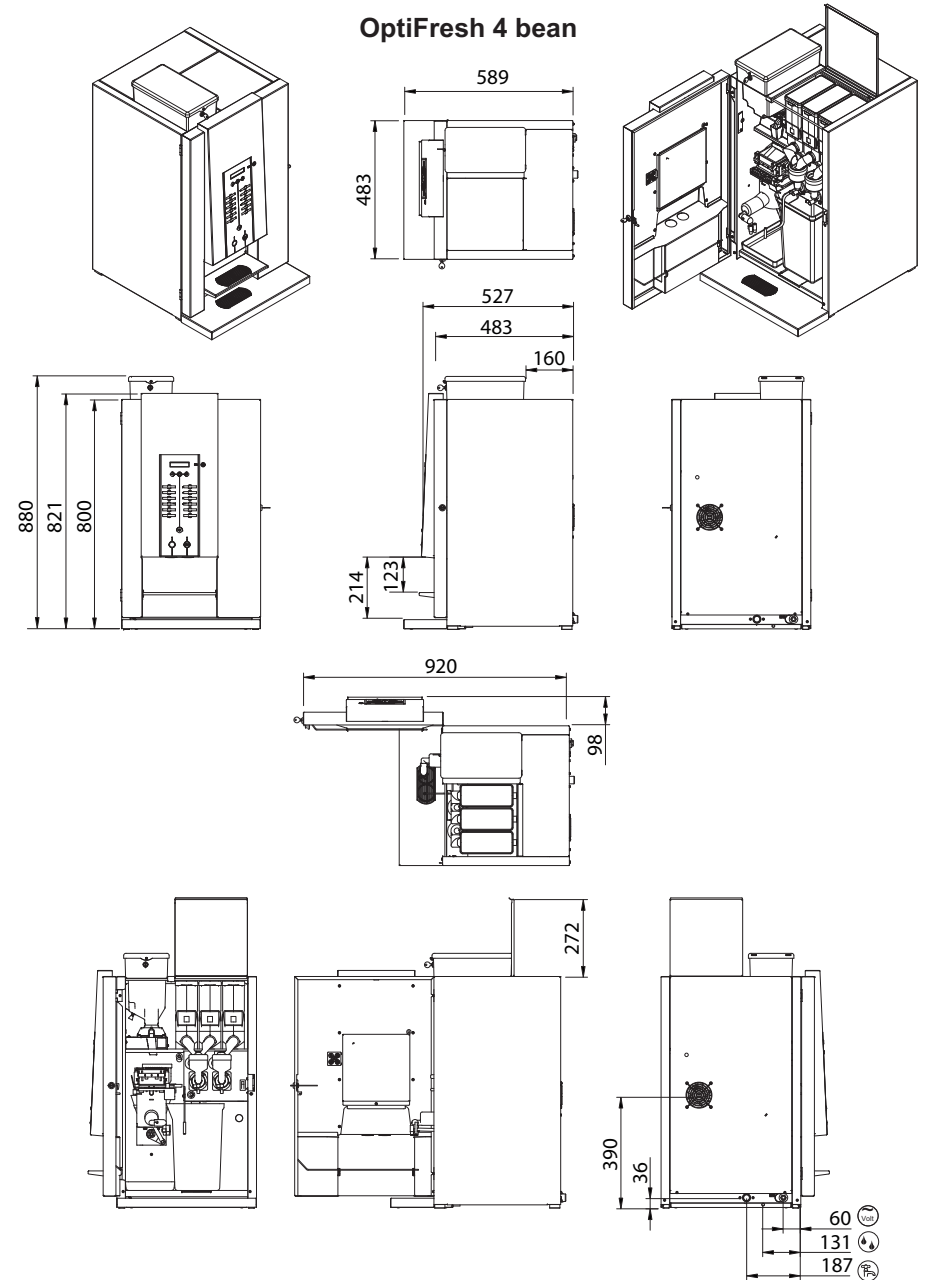

Afmetingen / Dimensions / Abmessungen / Dimensions

OptiFresh 1, 2, 3 bean Muntmechannisme / Coin system / Münzprüfer System / Système monnayeur

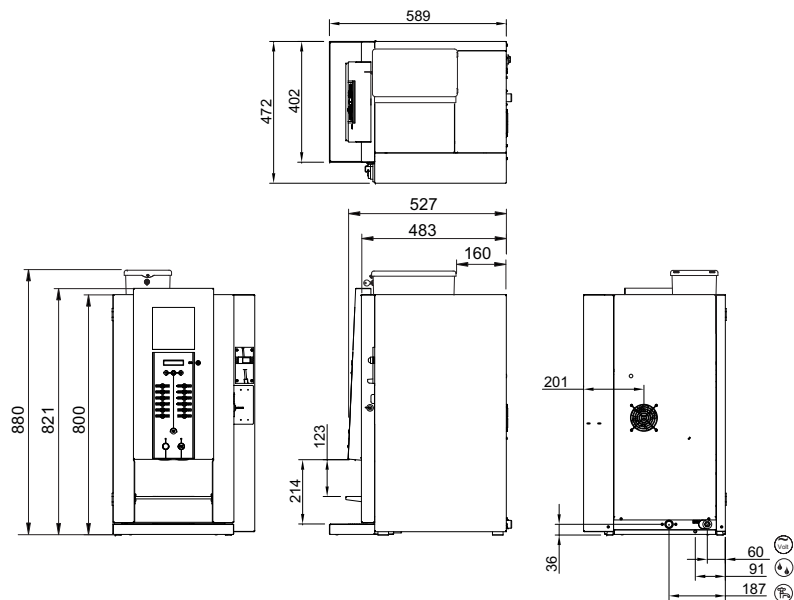

Afmetingen / Dimensions / Abmessungen / Dimensions

OptiFresh 1, 2, 3 bean Muntwisselaar / Coin changer / Münzwechsler / Monnayeurs-rendeurs

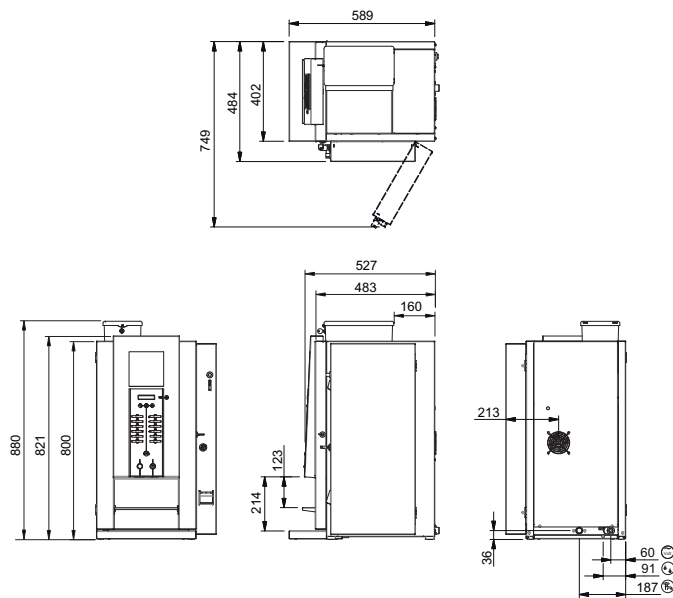

OptiFresh 4 bean Muntmechannisme / Coin system / Münzprüfer System / Système monnayeur

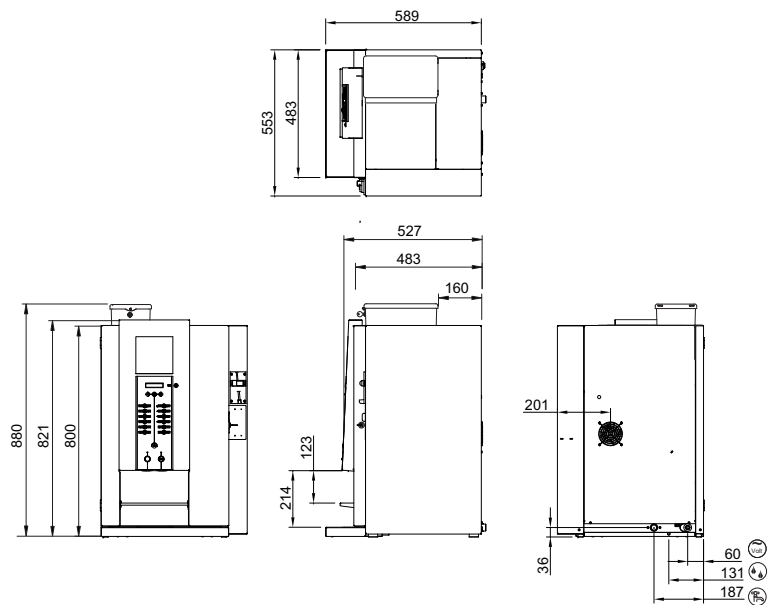

OptiFresh 4 bean Muntwisselaar / Coin changer / Münzwechsler / Monnayeurs-rendeurs

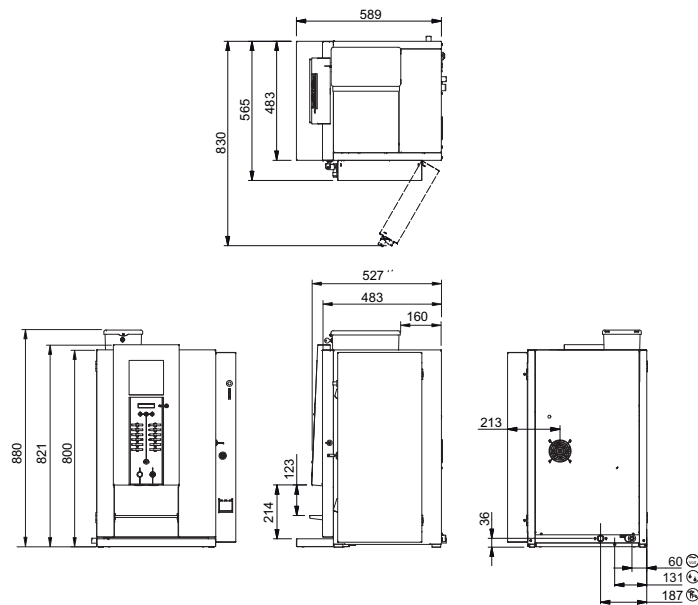

Afmetingen / Dimensions / Abmessungen / Dimensions

Onderkast / Base cabinet / Unterschrank / Table support

art.nr. 65070

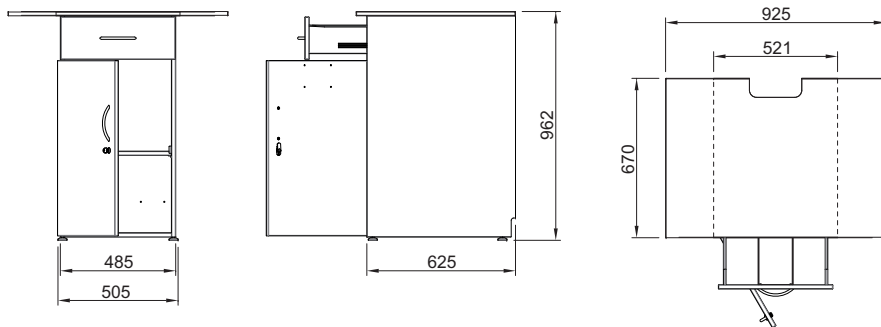

Met afvalbak / With waste bin / Mit Abfallbehälter / Avec trappe

art.nr. 65060

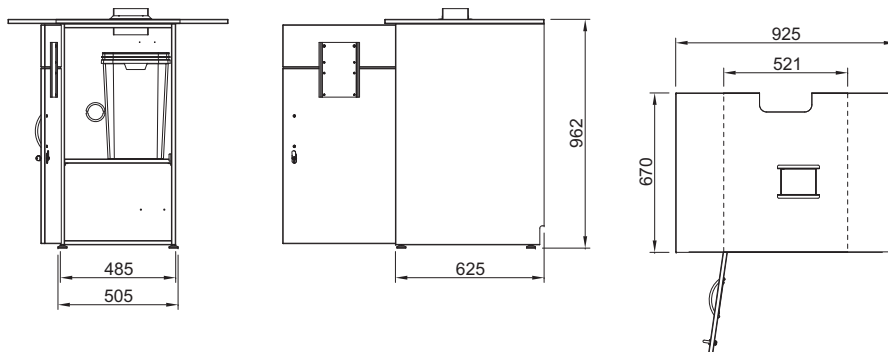

Animo®

OPTIFRESH bean

Animo B.V. Headoffice
 Dr. A.F. Philipsweg 47
 P.O. Box 71
 9400 AB Assen
 The Netherlands
 Tel. no. +31 (0)592 376376
 Fax no. +31 (0)592 341751
 E-mail: info@animo.nl
 Internet: <http://www.animo.eu>