

fig. 1

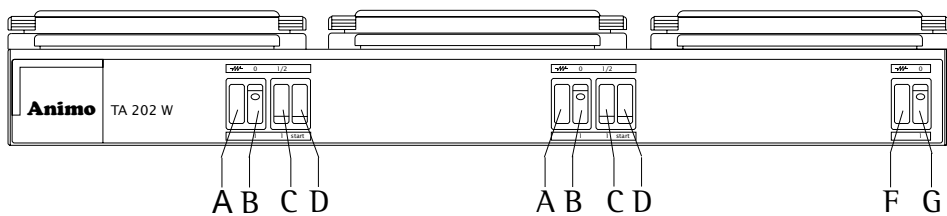

fig. 2

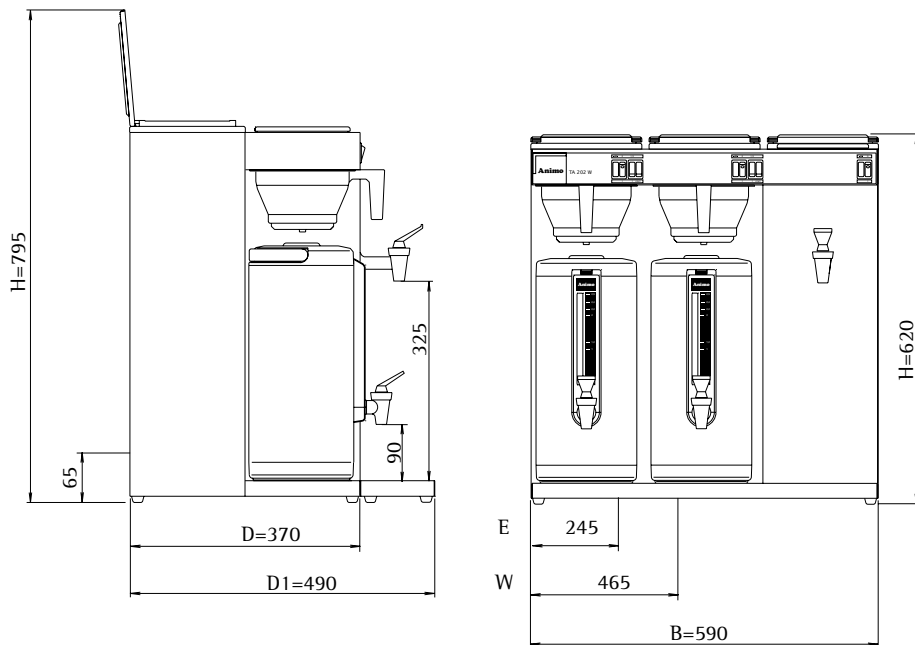
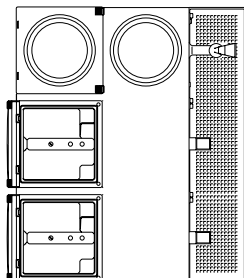

fig. 3

E = Electriciteitaansluiting

W = Wateraansluiting

Electrical supply

Water supply

Stromschnur

Wasseranschluß

Branchement électrique

Branchement d'eau froid



Dit apparaat voldoet aan de EMC-richtlijn 89/336/EEG, 92/31/EEG en de laagspanningsrichtlijn 73/23/EEG.

This appliance is in accordance with the EMC-Directive 89/336/EEC, 92/31/EEC and the low voltage directive 73/23/EEC.

Dieses Gerät wurde in Übereinstimmung gemäß EMV-Richtlinie 89/336/EWG, 92/31/EWG und Niederspannung-Richtlinie 73/23/EWG gebaut.

Cet appareil est conforme à la directive d'EMC 89/336/CEE, 92/31/CEE et à la directive de basse tension 73/23/CEE.

Animo behoudt zich het recht voor om onderdelen op elk gewenst moment te wijzigen, zonder voorafgaande of directe kennisgeving aan de afnemer. De inhoud van deze handleiding kan eveneens gewijzigd worden zonder voorafgaande waarschuwing. Deze handleiding is geldig voor de machine in standaarduitvoering. Animo kan derhalve niet aansprakelijk worden gesteld voor eventuele schade voortvloeiende uit van de standaard uitvoering afwijkende specificaties van de aan u geleverde machine. Voor informatie betreffende afstelling, onderhoudswerkzaamheden of reparaties waarin deze handleiding niet voorziet, wordt u verzocht contact op te nemen met de technische dienst van uw leverancier. Deze handleiding is met alle mogelijke zorg samengesteld, maar Animo kan geen verantwoording op zich nemen voor eventuele fouten in dit boek of de gevolgen daarvan.

Animo has the right to change parts of the machine at any time without advice or direct announcements to the client. The contents of this manual can also be changed without any announcements. This manual is to be used for the standard model/type of the machine. Thus Animo cannot be held responsible for any damage resulting from the application of this manual to the version delivered to you. For extra information on adjustments maintenance and repair, contact the technical department of your supplier. This manual has been written very carefully. However, Animo cannot be held responsible neither for mistakes in the book nor for their consequences.

Animo behält sich das Recht vor, Einzelteile ohne vorherige Bekanntgabe an den Kunden zu ändern. Der Inhalt dieser Anleitung kann ebenfalls ohne vorherige Bekanntgabe geändert werden. Diese Anleitung gilt für die Standardausführung der Maschine. Animo haftet daher nicht für Informationen über Einstellungen, Wartungsarbeiten oder Reparaturen, die nicht in dieser Anleitung enthalten sind. Wenden Sie sich bitte gegebenenfalls an den Kundendienst Ihres Händlers. Diese Anleitung wurde mit größtmöglicher Sorgfalt zusammengestellt. Animo haftet jedoch nicht für etwaige Fehler in dieser Anleitung oder für die Folgen solcher Fehler.

Animo se réserve le droit de modifier les pièces à n'importe quel instant, sans avis préalable et sans obligation de notification au client. Le contenu de ce manuel est également sujet à modification sans avis préalable. Ce manuel s'applique au modèle standard de la machine. Par conséquent, Animo n'est pas responsable pour les dommages éventuels découlant de l'application de ce manuel aux modèles non standard. Pour les renseignements sur certains réglages, les travaux d'entretien ou réparations qui ne seraient pas traités dans ce manuel, Animo ne peut être tenu responsable des erreurs éventuelles ni des dommages qui en découleraient.

TABLE OF CONTENTS

1.	GENERAL DESCRIPTION	2
2.	TECHNICAL DETAILS	2
3.	INSTALLATION	3
4.	CONTROL PANEL	4
5.	PREPARATION BEFORE USE	4
6.	HOW TO PREPARE FILTER COFFEE	5
7.	HOW TO DRAW OFF HOT WATER	5
8.	MAINTENANCE	5
8.1	How to descale the filter coffee unit	6
8.2	How to descale the hot water unit	6
9.	TEMPERATURE SECURITY	7

These operating instructions should be read carefully to ensure that your coffee machine is operated correctly and safely.

1. GENERAL DESCRIPTION

The Aromatic TA202 W is an automatic coffee machine with a permanent connection to the water supply. It operates on the principle of instantaneous water heating thus eliminating warm-up time. The machine consists of a double filter coffee unit and a separate water heater with a tap. The machine's hot water unit can be used to make tea, coffee, cocoa, cup-a-soup etc.

Figure 1.

A - Centre support for thermoscontainers	E - Water reservoir for hot water unit
B - Thermoscontainer 2.4L 2x (art.nr. 50241)	F - Hot water reservoir
C - Removable filters (90/250) 3x (art.nr. 08635)	G - Switch panel
D - Water reservoirs for filter coffee unit	H - Hot water tap

The machine is supplied with the following accessories:

- Measuring spoon
 - Approx. 50x paper coffee filters 90/250 (art.nr.01088 1000 pcs.)
 - Water supply hose approx. 1.25 m long
 - 2 sachet coffee detanning agent (100 sachets for 10 grams art.no. 49009)
 - 2 sachet descaling agent (48 sachets for 50 grams art.no. 49007)
 - Manual
- A matching drip tray (art.nr. 13024) can be supplied at an additional charge on request.

2. TECHNICAL DETAILS

Type: TA202 W	: 3N~ (tree phase)
Approx. hourly capacity coffee	: ± 40 L/h
Approx. hourly capacity hot water	: ± 20 L/h
Buffer supply coffee	: 4.5 L
Buffer supply hot water (approx)	: 3 L
Warm up time hot water (15-98°C)	: 12 min
Coffee preparation time (1.8 Liter)	: ± 7 min
Minimum amount of coffee	: 1/2 kan
Level detection	: electronic
Water connection	: G 3/4"
Min. - Max. water pressure	: 1-8 bar
Paper filter size	: 90/250
length of electric cable	: 2 m
Dimension	: zie fig. 3

Power supply (50/60 Hz)

	Capacity	Fuse
380V 3 live/neutral	5775W	10A
400V 3 live/neutral	6300W	10A
415V 3 live/neutral	6875W	15A

Technical alterations are reserved

3. INSTALLATION

Before installing the machine, carry out the following steps:

- Position the machine on a firm and even surface so that it can be connected to the electricity and water supplies.
- The TA202 W with automatic filling should be positioned near a manually-operated water tap. The water supply hose is 1.25 metres long.
- When positioning the machine, bear in mind that it is equipped with an overflow device.

The machine should be connected as demonstrated in the diagrams shown below, depending on the machine's electrical fittings.

- (Fig. 4) For 220V -240V 3 live (4 core electric cable).
- (Fig. 5) For 380V-415V 3 live/neutral (5 core electric cable).

The following points should be observed when wiring a new plug:

- The green/yellow-coloured wire ("EARTH") should be connected to the terminal which is either marked with the letter "E", the "earth" symbol (\perp), or coloured green or green/yellow.
- The blue-coloured wire ("NEUTRAL") should be connected to the terminal which is either marked with the letter "N" or coloured black.
- The brown-coloured wire ("LIVE") should be connected to the terminal which is either marked with the letter "L" or coloured brown.

IMPORTANT !

The four or five core mains cable (fig. 4/ fig. 5) has the following wiring code:

Green/Yellow	-	Earth
Blue	-	Neutral
Brown	-	Live
Black	-	Live

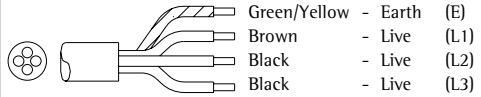

fig. 4

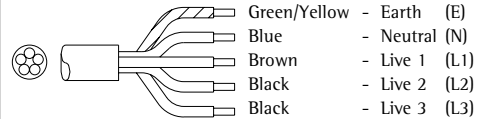

fig. 5

WARNING 

- * Always remove the plug from the socket if the machine has to be opened for repair or maintenance.
- * Do not position the machine in areas where the temperature drops below freezing point because there is always water left in the system.
- * Always plug the machine into an earthed wall socket.
- * Do not submerge or spray the machine.
- * Have all repairs carried out by a specially trained technician.
- * If the machine is not used it is advisable to remove the plug from the socket and the tum off the water tap.

4. CONTROL PANEL (FIG. 2)

- filter coffee unit
- A - Alarm lamp for heating element
- B - On/off switch
- C - Selection switch for full or half jug
- D - Start switch
- hot water unit
- F - Alarm lamp for heating element
- G - On/off switch

5. PREPARATIONS BEFORE USE

Before operating the machine, carry out the following steps:

- **filter coffee unit:**
 1. Connect the supplied water hose to the coupling nut swivel joint at the rear of the machine and to a manually-operated water tap. **ATTENTION!** Use cold water only.
 2. Pour 2 Liter of cold water in both the cold water reservoirs (fig. 1D).
 3. Wait for 3 minutes until the water has entered the entire system.
 4. Slide both removable filter into the machine and place an empty thermoscontainer under the filters.
- **hot water unit:**
 5. Remove the round black and stainless steel safety lid from the hot water reservoir (fig. 1F).
 6. Fill the hot water reservoir (fig. 1F) with 2 measuring jugs of water.
 7. After you have followed the instructions above, place the plug in the socket.
 8. Turn on the filter coffee unit using the switch (fig. 2B).
 9. Turn the selection switch (fig. 2C) to the desired amount.
 10. Press the start switch (fig. 2D) and the water reservoir will fill up.
 11. The orange alarm lamp (fig. 2A) on the filter coffee unit will now remain lit until the water has run through. The filter coffee unit is ready for use when the lamp has gone out again.

12. Switch on the hot water unit using the main switch (fig. 2G).
13. The water reservoir will fill up with water.
14. The orange alarm lamp (fig. 2F) in the hot water unit will light up until the hot water has reached the appropriate temperature.
15. Replace the lids on the hot water reservoir in the reverse order.
16. The machine is now ready for use.

6. HOW TO PREPARE FILTER COFFEE

- The steps for prepare filter coffee are equal for both filter coffee units.
1. Place a paper coffee filter (90/250) with the appropriate amount of coffee (fine ground for filter coffee units) in the removable filter. The amount can be measured with the supplied measuring spoon. Generally speaking, you will need about 90 - 100 gram per 2.25 L jug.
 2. Place an empty thermoscontainer under the filter.
 3. Check that the machine is switched on, main switch on (fig. 2B).
 4. Turn the selection switch (fig. 2C) to the required amount.
 5. Press the start switch (fig. 2D).
 6. The orange alarm lamp (fig. 2A) on the filter coffee unit will now light up and the filter coffee will be prepared.
 7. When the alarm lamp goes out again, the hot water supply will stop. After about 1 minute, all of the coffee will have poured through the filter.
 8. Stir the coffee in the thermoscontainer briefly and pour, or place the full thermoscontainer where it is need it.
 9. The machine is ready to be used again after the removable filter has been cleaned.

7. HOW TO DRAW OFF HOT WATER

1. Switch on the heating using the main switch (fig. 2G).
2. If the cold water reservoir contains insufficient water, it will always refill automatically to the correct level.
3. The orange alarm lamp (fig. 2F) lights up when the heating process starts.
4. When the alarm lamp (fig. 2F) goes out, the water has reached the correct temperature and the hot water tap can be used.

8. MAINTENANCE

- The machine can be cleaned with a clean, damp cloth.
- The thermoscontainer and removable filter can be cleaned in the same way. **Attention!** The removable filter and the thermoscontainer should not be placed in a dishwasher.
- Coffee stains in the thermoscontainer can be removed using Animo coffee stain remover.
- The machine can leave lime deposits during use. The machine should be descaled regularly in order to ensure that it functions efficiently. Animo scale remover is recommended.

It is advisable to descale both the filter coffee unit and the hot water unit in the same time.

Animo supplies both products in the following quantities:

- Coffee detanning agent
100 sachets for 10 grams art.no. 49009
- Descaling agent
48 sachets for 50 grams art.no. 49007

WARNING 

- Stay near the machine while maintenance is being carried out.
- When descaling the machine, always observe the instructions for use provided with the descaling agent.
- When descaling the machine, it is advisable to wear safety goggles and protective gloves.
- Allow the machine to run through at least three times after it has been descaling.
- Wash your hands thoroughly after descaling.
- The machine should not be submerged or sprayed.
- Have all repairs carried out by a specially trained technician.

8.1 How to descale the filter coffee unit

- The steps for descaling are equal for both filter coffee units.
 1. Switch off the machine (fig. 2B).
 2. Slide the removable filter into the machine
 3. Place an empty thermoscontainer under the filter.
 4. Dissolve 1 sachet for 50 grams of Animo descaling agent remover in 1 litre of lukewarm 60 -70°C water (see instructions for use on the labelling).
 5. Pour 1 litre of Animo descaling agent remover into the reservoir (fig. 1D) and switch on the machine (fig. 2B).
 6. Turn the selection switch (fig. 2C) to the half position and press the start button (fig. 2D). The solution will now begin to flow through the system.
 7. Leave the reservoir lid open!
 - * **Attention! If the machine begins to steam heavily, switch it off immediately (fig. 2B). Wait for 1 minute. The solution will flow through automatically. Switch the machine back on. Press the start button (fig. 2D) as well.**

8. When half of the solution has run through the machine, switch it off for about 2 minutes (fig. 2B). The solution will now undergo a reaction with the lime scale.
9. After the pause, switch the machine back on and allow the rest of the solution to flow through the machine. Press the start button again (fig. 2D).
 - * **Attention! Keep an eye on the reservoir while the solution is running through the machine. Turn the machine off as soon as the reservoir is empty. Then rinse clean the metal contacts in the cold water reservoir with water or a wet cloth.**
10. After descaling the machine, rinse thoroughly by carrying out the normal coffee preparation process 3 times (without paper filters and coffee).
11. Clean the removable filter and thermoscontainer thoroughly. The filter coffee unit is now ready to be used again.

8.2 How to descale the hot water unit

1. Remove the round black and the stainless steel lid from the hot water reservoir (fig. 1F).
2. Remove the larger pieces of deposit by holding the machine upside down above the sink so that the water and the loose pieces of scale fall out.

Attention! The coffee unit will also empty! (see unit 5, "Preparation before use").
3. Use a descaling agent to remove the remaining scale. The hot water unit should be refilled as described in unit 5, "Preparation before use".
4. As soon as the hot water unit has heated up, draw off one third (approx. 1.5L) of the hot water.

Attention! When the reservoir has reached the correct temperature, it should be switched off (fig. 2G). It should not be switched on again during the descaling process.
5. Add two sachets for 50 grams Animo descaling agent into the water. This will now undergo a (frothing) reaction with the scale deposits.
6. Allow the solution to soak in for about 10 minutes until the frothing has stopped.
7. Allow the hot water reservoir to drain until no more water comes out of the tap.

8. Switch on the machine (fig. 2G) and allow the hot water reservoir to return to the correct temperature.
9. The cold water reservoir fills itself automatically to the correct level.
10. Draw off at least 3 jugs of water through the tap.
11. The hot water unit is now ready to be used again

9. TEMPERATURE SECURITY

The hot water unit is supplied with a temperature security that can be accessed from the outside. The security is installed at the back of the device, next to the electricity cable connection. The security is activated when the temperature gets too high.

In case the security was activated, do the following:

1. Make sure the machine is cooled down.
2. Unscrew the black protective cover.
3. A button becomes visible. Press it and tighten the cover.

If you find the technical malfunction not to be caused by the temperature security, contact your dealer.

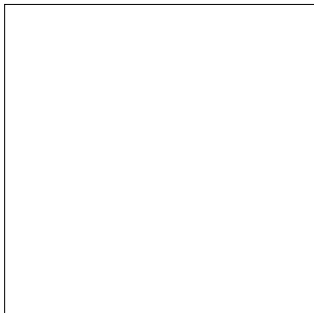
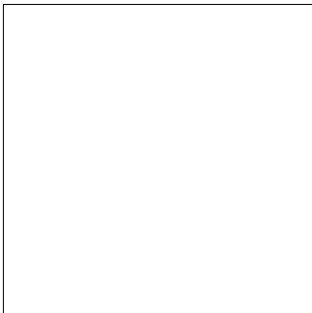
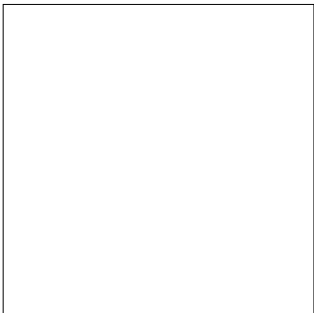
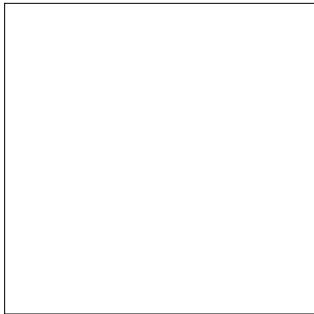
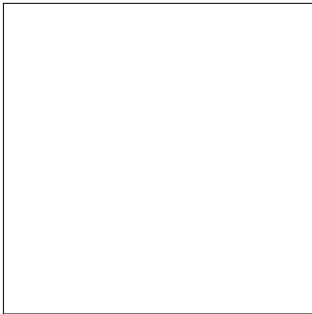
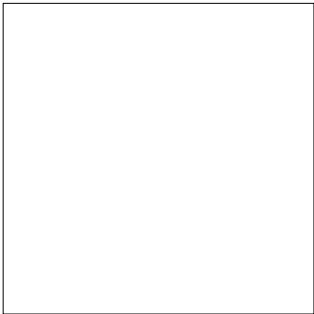

Animo B.V. Headoffice
Dr. A.F. Philipsweg 47
P.O. Box 71
9400 AB Assen
The Netherlands
Tel. no. +31 (0)592 376376
Fax no. +31 (0)592 341751
E-mail: info@animo.nl
Internet: <http://www.animo.nl>

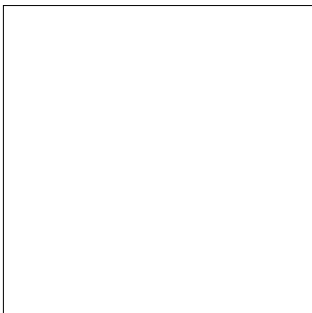

0297 Rev. 1 160989 **Animo** 09976



Accredited by
the Dutch Council
for Certification

