



Dit apparaat voldoet aan de EMC-richtlijn 89/336/EEG, 92/31/EEG en de laagspanningsrichtlijn 73/23/EEG

This appliance is in accordance with the EMC-Directive 89/336/EEC, 92/31/EEC and the low voltage directive 73/23/EEC

Dieses Gerät wurde in Übereinstimmung gemäß EMV-Richtlinie 89/336/EWG, 92/31/EWG und Niederspannung-Richtlinie 73/23/EWG gebaut.

Cet appareil est conforme à la directive d'EMC 89/336/CEE, 92/31/CEE et à la directive de basse tension 73/23/CEE.

Animo behoudt zich het recht voor om onderdelen op elk gewenst moment te wijzigen, zonder voorafgaande of directe kennisgeving aan de afnemer. De inhoud van deze handleiding kan eveneens gewijzigd worden zonder voorafgaande waarschuwing. Deze handleiding is geldig voor de machine in standaarduitvoering. Animo kan derhalve niet aansprakelijk worden gesteld voor eventuele schade voortvloeiende uit van de standaard uitvoering afwijkende specificaties van de aan u geleverde machine. Voor informatie betreffende afstelling, onderhoudswerkzaamheden of reparaties waarin deze handleiding niet voorziet, wordt u verzocht contact op te nemen met de technische dienst van uw leverancier. Deze handleiding is met alle mogelijke zorg samengesteld, maar Animo kan geen verantwoording op zich nemen voor eventuele fouten in dit boek of de gevolgen daarvan.

Animo has the right to change parts of the machine at any time without preceding or direct announcements to the client. The contents of this manual can also be changed without any announcements. This manual is to be used for the standard model/type of the machine. Thus Animo cannot be held responsible for any damage resulting from the application of this manual to the version delivered to you. For extra information on adjustments maintenance and repair, contact the technical department of your supplier. This manual has been written very carefully. However, Animo cannot be held responsible neither for mistakes in the book nor for their consequences.

Animo behält sich das Recht vor, Einzelteile ohne vorherige Bekanntgabe an den Kunden zu ändern. Der Inhalt dieser Anleitung kann ebenfalls ohne vorherige Bekanntgabe geändert werden. Diese Anleitung gilt für die Standardausführung der Maschine. Animo haftet daher nicht für Informationen über Einstellungen, Wartungsarbeiten oder Reparaturen, die nicht in dieser Anleitung enthalten sind. Wenden Sie sich bitte an den Kundendienst Ihres Händlers. Diese Anleitung wurde mit größtmöglicher Sorgfalt hergestellt. Animo haftet jedoch nicht für etwaige Fehler in dieser Anleitung oder für die Folgen solcher Fehler.

Animo se réserve le droit de modifier les pièces à n'importe quel instant, sans avis préalable et sans obligation de notification au client. Le contenu de ce manuel est également sujet à modification sans avis préalable. Ce manuel s'applique au modèle standard de la machine. Par conséquent, Animo n'est pas responsable pour les dommages éventuels découlant de l'application de ce manuel aux modèles non standard. Pour les renseignements sur certains réglages, les travaux d'entretien ou réparations qui ne seraient pas traités dans ce manuel, Animo ne peut être tenu responsable des erreurs éventuelles ni des dommages qui en découleraient.

TABLE OF CONTENTS

1.	GENERAL DESCRIPTION	4
2.	TECHNICAL DETAILS	4
3.	INSTALLATION	5
3.1	Placing the machine	5
3.2	Connection to the electricity supply system	5
4.	CONTROLS	6
5.	PREPARATION BEFORE USE	6
6.	MAINTENANCE	6
6.1	Descaling	6
7.	TEMPERATURE PROTECTION	7
8.	TRANSPORT	7

This instruction was designed for users of the Animo storage water heater, type WKT-D. Read this instruction carefully as it will ensure proper and safe use of the machine.

1. GENERAL DESCRIPTION

The storage water heater WKT-D can be installed wherever large volume of hot water is needed for example for instant coffee, tea, cocoa, soup etc. The WKT-D can fill both cups and small jugs. These storage water heaters are fitted for this purpose with a no-drip tap which is easy to operate. The WKT-D is double-walled and has polyurethane insulation (CfC free).

In figure 1 the main parts are indicated.

- A - Insulated cover
- B - Handle
- C - Level gauge with litre index scale
- D - Hot water no-drip tap
- E - Indicator light
- F - Adjustable thermostat
- G - Dry-boil safety guard
- H - Electrical supply

The machine is supplied with the following accessories:

- Manual
- 1 sachet descaling solvent
(100 sachets at 50 gram art.no. 49009-K)

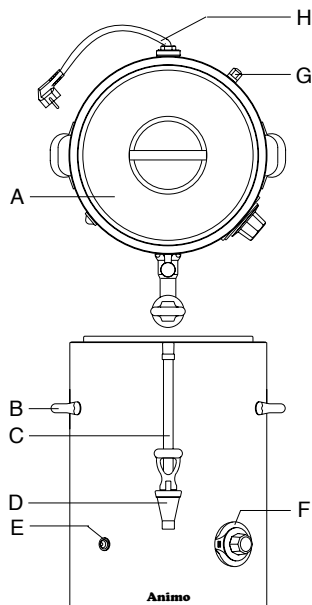

fig. 1

2. TECHNICAL DETAILS

Type	: WKT-D 10	WKT-D 18
Volume	: 10 Litre	18 Litre
Hour capacity	: ca. 30 L/h	ca. 30 L/h
Heating time 20-97°C	: ca. 24 min.	ca. 40 min.
Electrical connection	: 1N~ 220-240V	1N~ 220-240V
Frequency	: 50-60Cy	50-60Cy
Power	: 3,2 kW	3,2 kW
Dimensions Ø x H	: 305x430mm	305x580mm
Tap outflow height	: 120mm	120mm
Weight	: 9 kg	11 kg

Technical alterations are reserved

WARNING

- * Always remove the plug from the socket if the machine has to be opened for repair or maintenance.
- * Do not position the machine in areas where the temperature drops below freezing point because there is always water left in the system.
- * Always plug the machine into an earthed wall socket.
- * Do not submerge or spray the machine.
- * Have all repairs carried out by a specially trained technician.
- * During use, some parts will become very hot.
- * In case the machine is not used for a relatively long time, it is advisable to remove the plug from the socket.

3. INSTALLATION

Follow the instructions to place and connect the machine, specified below.

3.1 Placing the machine

Place the unit:

- at counter level and on a solid flat surface.
- where it can be connected to the electricity grid.
- Such that it is not causing any damage in case of leakage.

3.2 Connection to the electricity supply system

Depending on the model, the appliance should be connected according to the instructions in the figures below.

- (fig. 2) For 240V 1 phase with plug socket.
- (fig. 2) For 240V 1 phase (3-core cable).

The following remarks apply to figure 2:

- If the plug fitted on the machine cable does not fit to your socket, replace it with a new plug that does fit.
- The replaced plug should be disposed of as it can be dangerous if plugged in a socket.

The following points should be observed when wiring a new plug:

1. The green/yellow-coloured wire ("EARTH") should be connected to the terminal which is either marked with the letter "E", the "earth" symbol (\perp) or coloured green or green/yellow.
2. The blue-coloured wire ("NEUTRAL") should be connected to the terminal which is either marked with the letter "N" or coloured black.
3. The brown-coloured wire ("PHASE") should be connected to the terminal which is either marked with the letter "L" or coloured red.

IMPORTANT!

The 3 core main cable (fig. 2) has the following wiring code:

Green/yellow - Earth
Blue - Neutral
Brown - Phase



Fig. 2

4. CONTROLS

- 1 - Heating indicator light (fig. 1E)
- 2 - Adjustable thermostat (fig. 1F)

5. PREPARATIONS BEFORE USE

The following procedure should be carried out before a new appliance is used.

1. Remove the cover of the storage water heater.
2. Fill the storage water heater with water, till the mark on the litre index scale.
Never overfill the reservoir.
3. Replace always the cover of the storage water heater.
4. Put the plug fitting in the socket and switch the machine on by turning the thermostat to the required temperature (fig. 1F).
5. The indicator light (fig. 1E) will now light up until the water has reached the correct temperature.
6. When the indicator light goes out, the storage water heater is ready for use. During use the indicator light will regularly on and off, to show that the water is heating up.
7. Check regularly (after draining of hot water) if the water heater needs refilling.

Draw off an amount of hot water, when the machine is used for the first time.

6. MAINTENANCE

- ◇ Clean the machine with a clean damp cloth.
- ◇ Avoid using abrasive. It can cause scratches and dim spots.
- ◇ Remove scale deposits by dull patches using

WARNING

- Stay near the machine while maintenance is being carried out.
- When descaling, always follow the instructions of the descaling agent used.
- It is advisable to wear protecting glasses and gloves during descaling.
- Allow the machine to run through at least three times to rinse the solution from the system after it has been descaled.
- Wash your hands thoroughly after descaling
- The appliance should not be submerged or hosed off.
- Make sure all the repairs to the appliance are carried out by a qualified technician.

6.1 Descaling

During operation scale will form in the machine. Therefore the machine needs to be descaled approx. once per month to guarantee the lowest energy consumption and proper functioning.

When to descale?

- Dependent on the frequency of usage and the hardness of the water, we advise to inspect the unit visually regular for scale formation.
 - Remove the cover of the storage water heater regular; If there is loose scale grid on the bottom, or if there is severe scale formation on the walls, then the unit needs descaling.
 - In some cases it is sufficient to remove loose scale grid.
1. Switch off the machine and remove the plug from the wallsocket.
 2. Remove the cover from the storage water heater.
 3. Turn the machine upside down over the sink. Loose scale grid will then come out.
 4. When there is no more scale in the machine, it can be operated as usual. Consult section 5 "Preparation before use".

To remove remaining scale formation use ANIMO descaling solvent.

5. Carefully read the caution notice and the directions on the sachet ANIMO descaling solvent.
6. Dissolve 1 sachets of 50 gram ANIMO descaling solvent into 2 litres of warm water.
7. Fill the hot water reservoir with the solution. This will now undergo a reaction with the scall deposits.
8. Allow the solution to soak in for about 10 minutes until the frothing has stopped.
9. Tap some of the acid off and pour it back into the reservoir.
10. Turn the machine upside down above the sink. Rinse the reservoir and the hot water tap clean with hot water.
11. When there is no more scale in the machine, it can be operated as usual. Consult section 5 "Preparation before use".

7. TEMPERATURE PROTECTION

There is a temperature protection in the machine that can be accessed from the outside. This protection is located at the back of the machine (fig. 1G). This protection is activated when the temperature gets too high. The most common cause for activating the security is scale that has not been removed in time.

If the temperature protection operates proceed as follows:

1. Let the unit cool down.
2. Unscrew the black protection cover.
3. Push the button, that now appears and replace the black cover and fasten it tightly.

When the protection was triggered due to scale formation, then proceed according to section 6.1 When the cause was not in scale formation, please contact your dealer.

8. TRANSPORT

Proceed as followed to transport the unit:

1. Switch the machine off and remove the plug from the wallsocket.
2. Remove the cover of the reservoir.
3. Turn the machine upside down to let the remaining water out above the sink.
4. Replace the cover.
5. The machine is now ready for transportation.
6. Proceed with section 3 "Installation" to reinstall the machine.

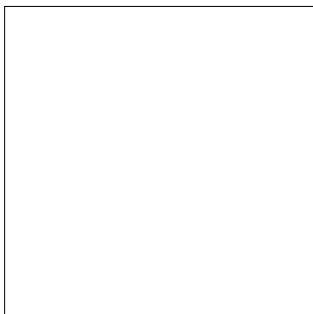
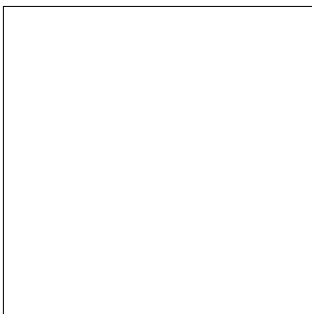
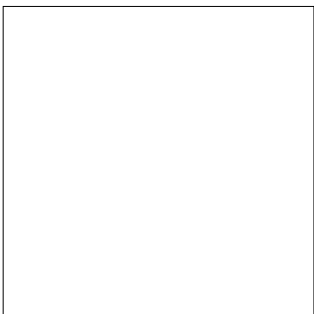
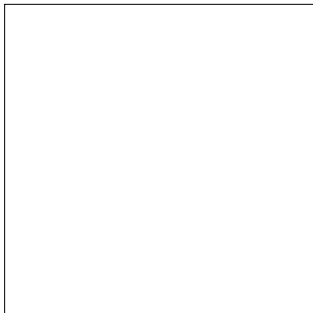
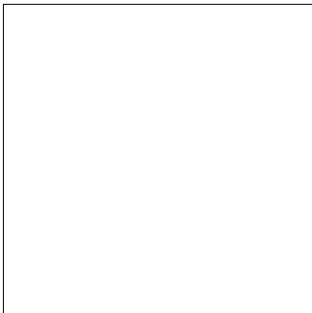
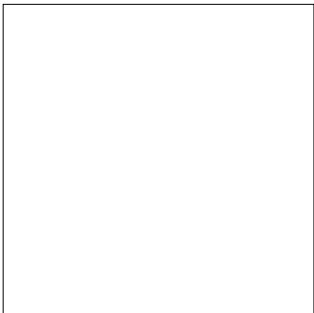
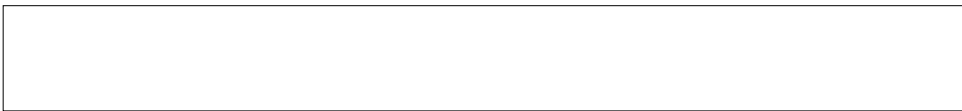

Animo B.V. Headoffice
Dr. A.F. Philipsweg 47
P.O. Box 71
9400 AB Assen
The Netherlands
Tel. no. +31 (0)592 376376
Fax no. +31 (0)592 341751
E-mail: info@animo.nl
Internet: <http://www.animo.nl>

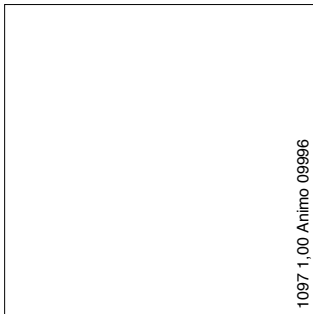
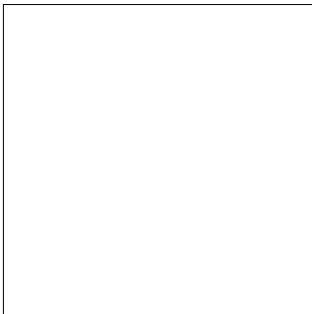

1097 1.00 Animo 09996



Accredited by
the Dutch Council
for Certification

